

Instruction, Use and Maintenance Manual

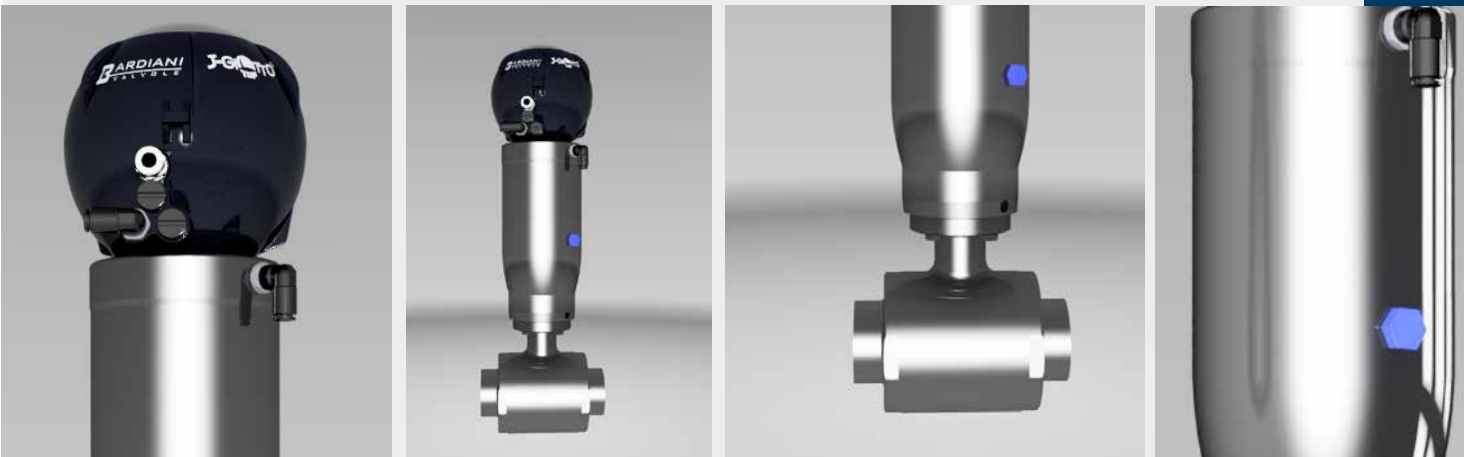

PNEUMATIC BALL VALVE **ZVS**

Bardiani Valvole S.p.A.

via G. di Vittorio, 50/52 - 43045 Fornovo di Taro (PR) - Italy
tel. +39 0525 - Fax 0525 3408
bardiani@bardiani.com - www.bardiani.com

MANUAL REVISION	DATE

INDEX

1	Safety, Warning and Mandatory Signs	5
2	General safety warnings	8
3	Technical data	9
4	Checking / Unpacking / Lifting	10
5	Installation	11
6	Operation	13
7	Troubleshooting	14
8	Cleaning	15
9	General maintenance	16
10	Scheduled maintenance	18
11	Tools useful for Disassembly/Reassembly	19
12	Pneumatic Ball Valve ZVS	20
13	Disassembly of the ZVS	21
14	Assembly of the ZVS	22
15	Annexes	26
16	2D diagram ZVS DN10--65	27
17	2D diagram ZVS DN65--100	28
18	Warranty	29
19	Recommendations	30

INTRODUCTION

This "Instruction, Use and Maintenance Manual" has been prepared to provide guidance and recommendations to assist qualified skilled technicians in the understanding, running and maintenance of the Products supplied.

It forms an integral part of the Products supplied and must be read prior to any installation, operation and/or maintenance of all types of valves provided.

This manual must be saved for future reference and be kept readily available at the unit.

With regards to the use of valves compliant with EU Directive 2014/34/UE (ATEX), consultation of a specific manual is mandatory.

The essential characteristics of all types of valves described herein being consistent, the Manufacturer reserves the right to alter and or complement and or update at any time and with no obligation to notify so in writing, the data and or information relevant to the use of the valves described in this "Instruction, Use and Maintenance Manual".

A constantly updated version of this "Instruction, Use and Maintenance Manual" is available at the Manufacturer's website www.bardianivalvole.it.

Under no circumstance shall the Manufacturer be held liable for consequences resulting from failure and or improper use of the instructions contained in this Manual and relating to the installation, operating, maintenance and storage of the products.

All rights reserved.

Full or part reproduction, transfer and or recording of any part of this "Instruction, Use and Maintenance Manual" by all means, whether it be electronic, on hard copy, mechanical or any other means or recording or reuse is strictly prohibited without the prior written consent of the Manufacturer and for any use other than that of the Buyer.

(Translation of the Original Instructions in the italian Language)

1 Safety, Warning and Mandatory Signs

WARNING SIGNS		
Pictogram	Description	Notes
	WARNING! General	This tells the person in question that the operation described involves (when not performed in accordance with the relative safety regulations) the risk of personal injury.
	WARNING! Hand crushing	Exercise caution in executing the procedure Hand crushing hazard
	WARNING! Heavy loads	Exercise caution in executing the procedure Heavy suspended loads.
	WARNING! Severe burns	Heat emission hazard Very hot surface, risk of severe burns
	WARNING! Risk of explosions	Take Care, risk of explosions

MANDATORY SIGNS (FOR THE OPERATOR IN CHARGE OF ASSEMBLY/DISASSEMBLY)		
Pictogram	Description	Notes
	OBLIGATION General	Special instructions must be followed to avoid injury to persons.
	PROTECTIVE GLOVES	Safety gloves must be available for handling objects which could cause hand injuries.
	HARD HAT	A hard hat must be worn during machine lifting operations to protect against hazards generated by suspended loads.
	FOOTWEAR	Use safety footwear to protect against the risks of falling objects during operations to transport the machine.
	SUITABLE CLOTHING	Suitable clothing such as overalls. It is strictly prohibited to wear clothes with large flapping sleeves and/or other loose items which could easily get caught up in machine parts.

MANDATORY SIGNS (FOR THE OPERATOR IN CHARGE OF MECHANICAL MAINTENANCE)		
Pictogram	Description	Notes
	OBLIGATION General	Special instructions must be followed to avoid injury to persons.
	PROTECTIVE GLOVES	Protective gloves must be available for handling objects which could cause hand injuries or when there is the possibility of coming into contact with harmful substances..
	HARD HAT	Hard hats must be available when lifting heavy parts.
	FOOTWEAR	Use safety footwear to protect against injuries caused by falling objects during maintenance operations (particularly when dismantling parts).
	SUITABLE CLOTHING	Suitable clothing such as overalls. It is strictly prohibited to wear clothes with large flapping sleeves and/or other loose items which could easily get caught up in machine parts.
	SAFETY GLASSES	Protective glasses must be available when there is the possibility of contact which harmful substances which could cause eye injuries.

OPERATING SIGNS		
Pictogram	Description	Notes
	PERSONAL PERSONNEL	Dismantling/Assembling and maintenance operations must be carried out by expert technicians only.
	NOTE	Follow the indicated note with care
	ENVIRONMENTAL NOTE	Follow the regulations in force in the country of used governing waste disposal.
	CLAMP	Use of a clamp
	CLAMP WITH SOFT JAWS	Use of a clamp with jaws made from soft material

OPERATING SIGNS		
Pictogram	Description	Notes
	PRESS	Use of a press
	PRESS (release)	Use of a press Gradual release of the pressure force
	ELECTRICAL CONNECTION	Electrical connection to the control unit (consult the relative instruction manual).
	ELECTRICAL DISCONNECTION	Electrical disconnection from the control unit (consult the relative instruction manual).
	PNEUMATIC CONNECTION	Connection of the air to the valve.
	PNEUMATIC DISCONNECTION	Disconnection of the air from the valve
	APPLICATION OF FOODSAFE GREASE	Use FOODLUBE HI-TEMP 2 15254 grease only
	APPLICATION OF FOODSAFE GREASE	Use FOODLUBE Multi-paste 15756 grease only
	APPLICATION OF MULTIPURPOSE GREASE	Use AGIP GREASE MU EP 2 SE 463754 only
	THREADLOCK APPLICATION	Use SPEED BOND M500 threadlock only
	OPTIONAL	

2 General safety warnings

Intended use

Bardiani valves have been designed exclusively for moving fluids.

Prohibited use

The valve must not be used:

- for any operations different to those described under the heading “Intended Use”,
- for handling fluids different to the type specified by the manufacturer;
- for moving fluids at different pressures to those envisaged by the manufacturer and indicated in the valve's technical data.

Limitations on valve use

It is forbidden to:

- use the valve in a construction configuration different to the one envisaged by the manufacturer.
- use the valve where there is a risk of explosion and/or fire, unless envisaged by the manufacturer (if the valves are certified in accordance with Directive 2014/34/EU, please refer to the ATEX Manual)-;
- integrate other systems and/or equipment which were not considered by the manufacturer during the executive design phase,
- use the valve for purposes other than those specifically envisaged by the manufacturer.



WARNING!

The machine may not be used inside premises where there is a potentially explosive atmosphere or risk of fire unless otherwise stated by the manufacturer (in the case of valves certified in accordance with Directive 2014/34/EU please refer to the ATEX Manual).



BARDIANIVALVOLES.p.A. declines all liability for installation, use or maintenance which fails to comply with the indications provided in this manual!

3 Technical data

VALVE DATA	
Maximum seal pressure	See catalogue
Product minimum - maximum temperature	From -20°C to 160°C for applications with air. Depending on the material used for the gaskets and the product
Storage temperature	from -10°C to 25°C
Material in contact with the product	AISI 316L (1.4404). Check the resistance to corrosion in relation to products and detergents
Gasket material in contact with the product	P.T.F.E. Check compatibility with products and detergents

PNEUMATIC ACTUATOR DATA	
Connectors	1/8" (BSP)
Air pressure	From 6bar to 8 bar
Material	AISI 304L
Gaskets material	NBR
Electrical power supply	See Giotto Top

The valve is complies with PED 2014/68/EU directive, with special reference to Annex III, Module A, concerning internal manufacturing checks as indicated in the Conformity Assessment Procedures.

The DN15--25 valves are included in compliance with Article 4, paragraph 3:

Valves designed for use with gas, liquid gas, gases dissolved under pressure, steam and those liquids with a vapour pressure at maximum admissible temperature exceeding 0.5 bar at normal atmospheric pressure (1.013 mbar) within the following limits:

- For group 1 fluids when DN is from 25 to 100.
- For group 2 fluids when DN is 125 and over.

In the event of any doubt, please contact Bardiani Valvole S.p.A.

4 Checking / Unpacking / Lifting

1. CHECK:

- Check the valve show no signs of damage caused during transport and that it corresponds with the order;
- Check the inside of the valve.



2. UNPACKING

The valve packaging is made up of cardboard, wood and plastic. The valve is mainly made up of metal materials. The gaskets are usually made from elastomers. Disposal must be in compliance with local legislation.



3. VALVE LIFTING:

Take care as to the type of valve you are handling. Based on the size there are different lifting procedures.



CAUTION!

Before lifting the valve, make sure there are no disassembled or separate valve parts which could fall off causing injury to persons and damage to the valve.

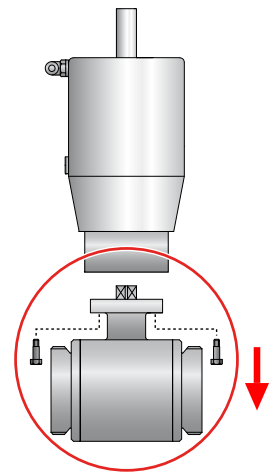
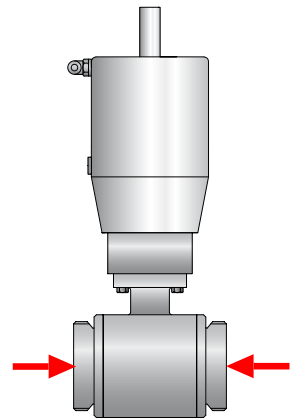

ZVS	
Size DN	Weight Kg
15--50	A
65--150	B

A

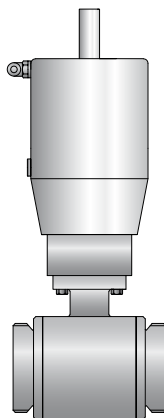

Weight up to 25 kg

B

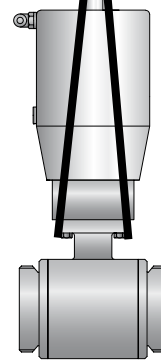

Weight between 25 kg and 50 kg



CAUTION!

The figures above are used purely to represent the methods and procedures for hoisting the valves. Bardiani Valvole S.p.A. declines all liability for any damage to things and/or injuries to persons caused by improper and/or incorrect hoisting of the valve.

5 Installation



1. ELECTRICAL AND PNEUMATIC ENERGY SUPPLY

- Use expert personnel for installation/uninstallation operations;
- Check that the air pressure and quality are correct (see "Technical Data");
- Check the power supply to the control unit is correct (consult the relative instruction manual).

A = Upward movement of the piston

B = Downward movement of the piston

In single acting valves there is only one of the aforementioned commands.

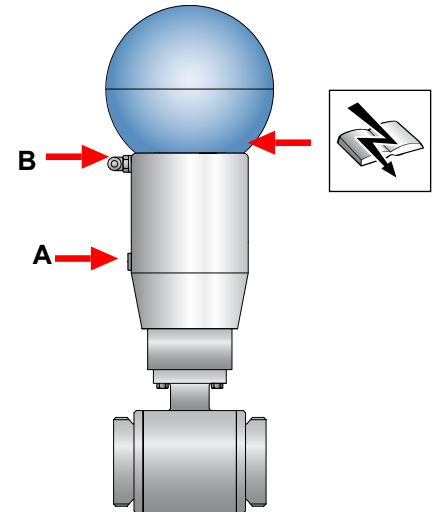

1. REDUCING THE STRESS TO WHICH THE VALVE IS SUBJECTED:

- Vibrations;
- Thermal expansion of the piping;
- Excessive welding;
- Overload.



CAUTION!

The seal seats may become deformed or cause valve malfunctioning.

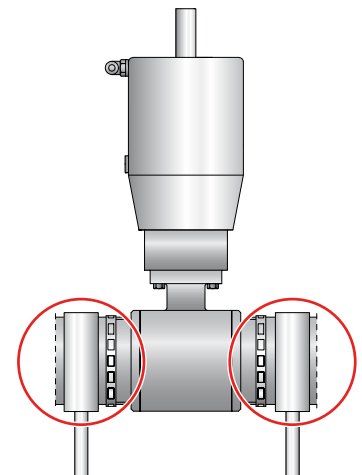

CAUTION!

Bardiani Valvole S.p.A. declines all liability for any damage to things and/or injuries to persons caused by any failure to correctly follow the installation procedures.



2. VALVE CONNECTIONS/CONNECTORS:

If the valve is fitted with connectors, you may proceed with installation. Correctly insert the gaskets and tighten the connectors.

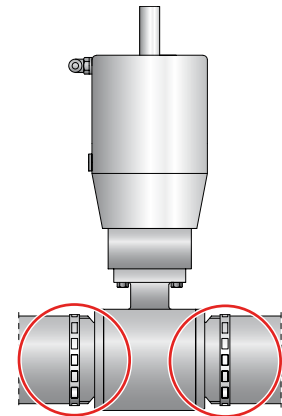

3. WELDING THE VALVE BODY ONTO PIPING:

Remove the body from the rest of the valve before proceeding with welding operations. Please refer to the following pages in this manual.

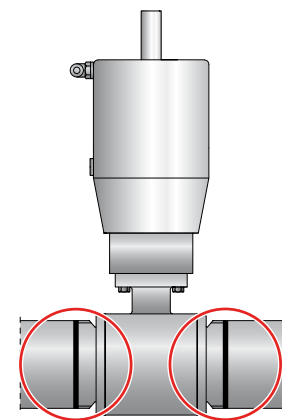

WARNING!

Hand crushing hazard.



4. MINIMUM MAINTENANCE CLEARANCES:

Make sure there is enough room to disassemble the valve.

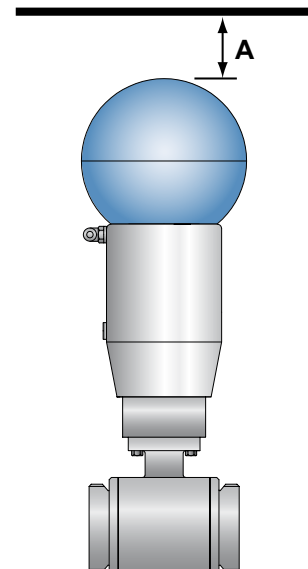

ZVS	
Valve dimension (DN)	A (mm)
10--65	210
65--100	220



CAUTION!

Bardiani Valvole S.p.A. declines all liability for any damage to things and/or injuries to persons caused by any failure to correctly follow the installation procedures.

6 Operation



1. VALVE INSPECTION BEFORE OPERATION:

- Supply air to the actuator;
- Power the valve (via the control unit);
- Open and close the valve several times;
- Check that the valve works correctly and accurately.

A = Downward movement of the piston

B = Upward movement of the piston

In single acting valves there is only one of the aforementioned commands.



WARNING!

Hand crushing hazard.

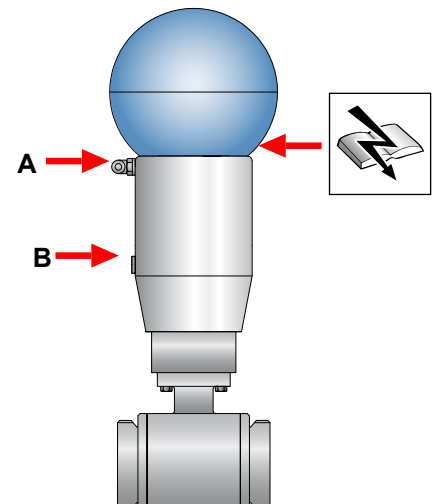

7 Troubleshooting



PROBLEM	POSSIBLE CAUSE	POSSIBLE SOLUTION
External leak	Worn gasket	Replace the seal
Leaks inside the closed valve caused by normal wear		
External leak	Excessive pressure	Replace with a gasket of a different type of elastomer
	Excessive temperature	
Premature leaks inside the closed valve	Aggressive fluids	Modify the operating conditions
	Too many commands active	
Difficulty opening and closing	Incorrect type of elastomer used for the gaskets	Replace with a gasket of a different type of elastomer
	Incorrect positioning of the actuator	Install the actuator correctly
	Incorrect operation of the actuator	Change from normally open (NO) to normally closed (NC) or vice versa.
	Impurities in the actuator	Inspection and maintenance of the actuator
	Incorrect valve body positioning	Dismantle and reposition the valve body correctly

8 Cleaning



1. VALVE CLEANING WITH DETERGENTS:

The system in which the valve is installed must be cleaned by expert personnel in observance of the following:

- Abide by the indicated detergent concentration values;
- Observe the instructions provided by the detergent manufacturer.
- Always wear protective safety glasses and gloves.



IMPORTANT!

- Accurately dose detergents to avoid excessive concentration;
- Always rinse thoroughly with clean water after washing.
- Check compatibility of valve materials.

Risk of damage elastomers

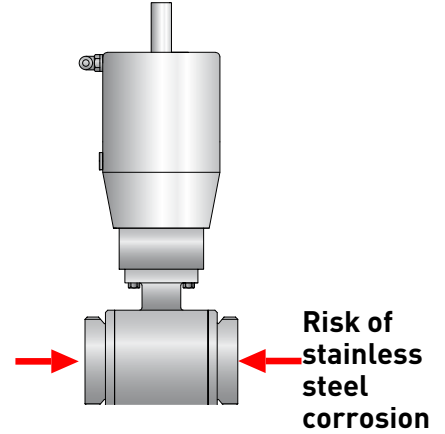

Risk of stainless steel corrosion



WARNING!

Burns hazard. The valves and piping may be very hot. Wear protective gloves



WARNING

After installing a new or serviced valve, perform an internal washing cycle before using the piping for food liquids. If there has been any welding work, passivation treatment must be carried out.

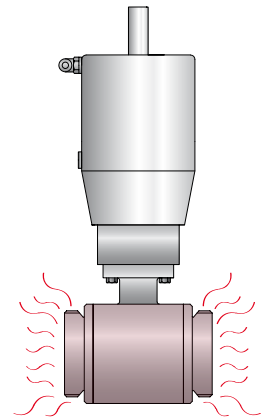

EXAMPLE OF INTERNAL WASHING CYCLE (CIP)		
Phases	Temperature °C	Washing product
Initial rinse	Environment	Chlorine- and chloride-free water
Washing	70 °C	Caustic soda (NaOH) at 1%
Intermediate rinse	Environment	Chlorine- and chloride-free water
Washing	70 °C	Nitric acid (HNO3) at 0.5%
End rinse	Environment	Chlorine- and chloride-free water

Recommended washing product velocity = 2m/s

9 General maintenance



1. MAINTENANCE PRECAUTIONS

Maintenance operations must be carried out by expert technicians only.



WARNING!

Maintenance operations must be carried out with the line stopped and all utilities (electricity, compressed air) disconnected.



WARNING!

Always discharge the fluid pressure in the valve and piping before disassembling the valve.



WARNING!

Burns hazard. The valves and piping may be very hot. Wear protective gloves

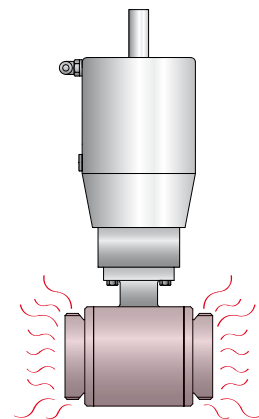
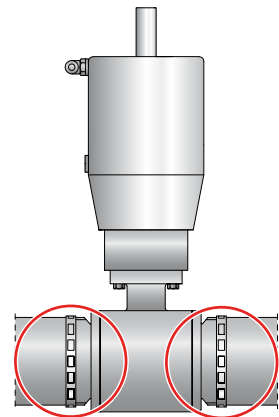



2. CLEANING AWAY DEPOSITS:

- Thoroughly wash and clean all the valve parts before disassembly;
- Pay attention to any possible detergent or other aggressive fluid deposits (see "Cleaning");
- Always use protective safety glasses and gloves when required.

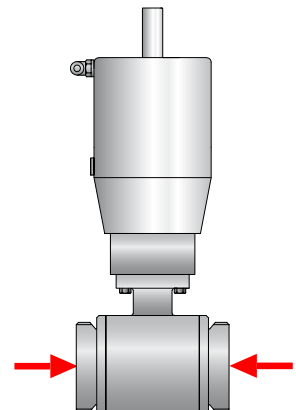

WARNING!

Hand crushing hazard.



3. REPLACEMENT OF WORN VALVE PARTS:

Always use original spare parts

10 Scheduled maintenance

SCHEDULED MAINTENANCE	VALVE GASKETS	ACTUATOR GASKETS
Preventive	Replace after 12 months	Replace after 24 months
In the event of leaks	Replace at the end of the day	Replace in the event of leaks
Periodical	Check correct operation and that there are no leaks	Check correct operation and that there are no leaks
	Record the actions carried out	Record the actions carried out

11 Tools useful for Disassembly/Reassembly

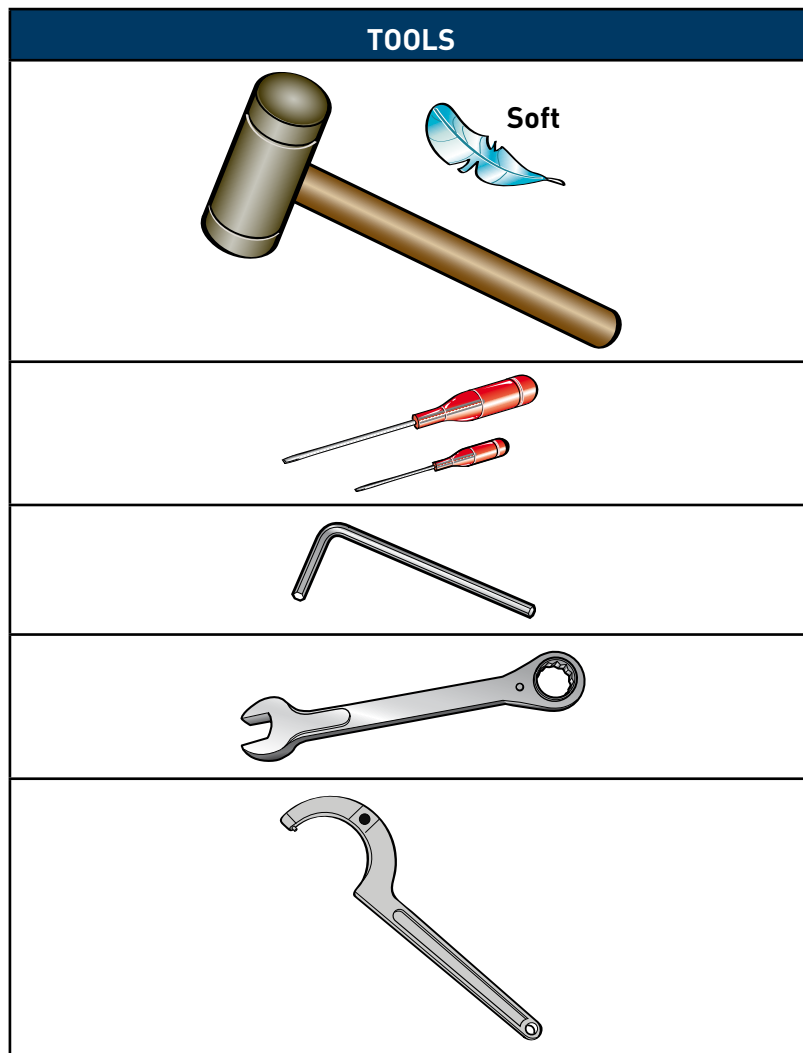

12 Pneumatic Ball Valve ZVS

NO.	DESCRIPTION
137	Screw
143	2-way body
143	3-way body
145	Assembly piece
234	Screw

(DN 10--65)

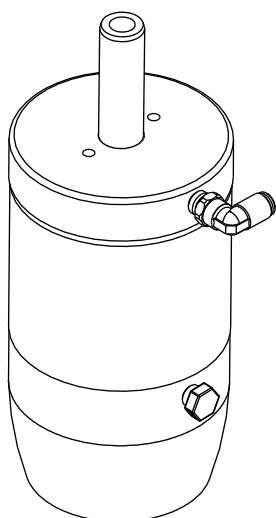

(DN 65--100)

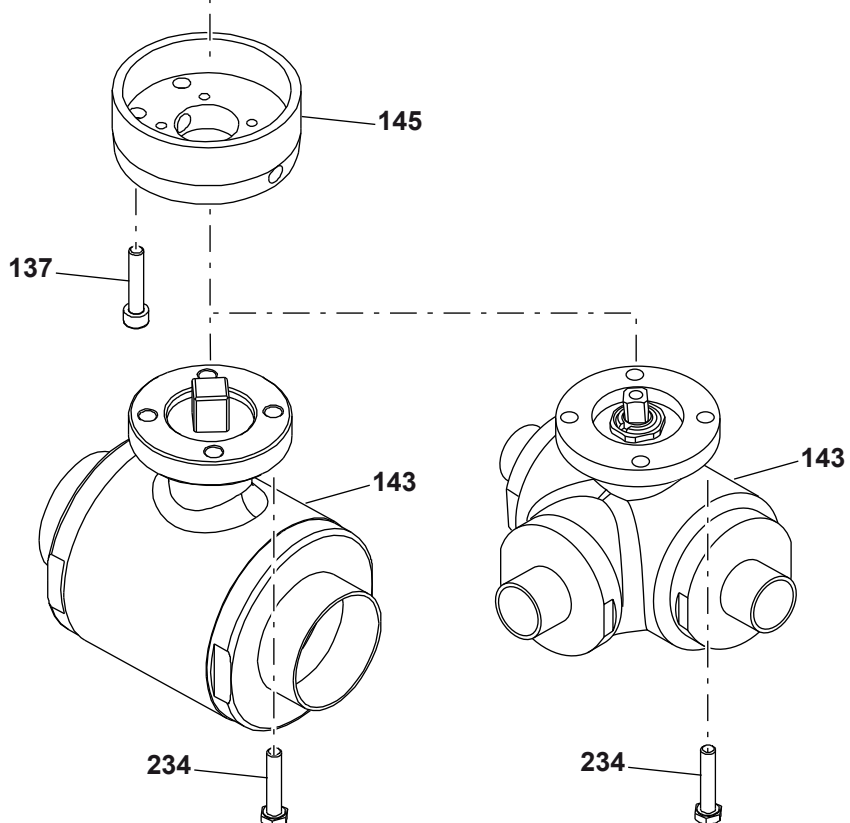
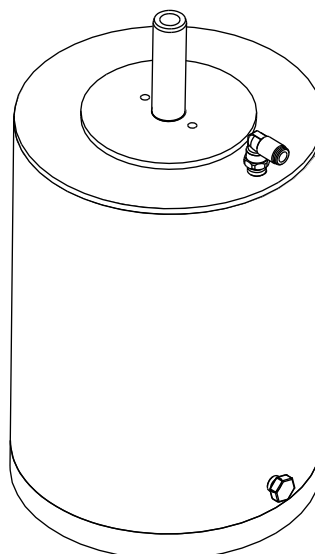

13 Disassembly of the ZVS

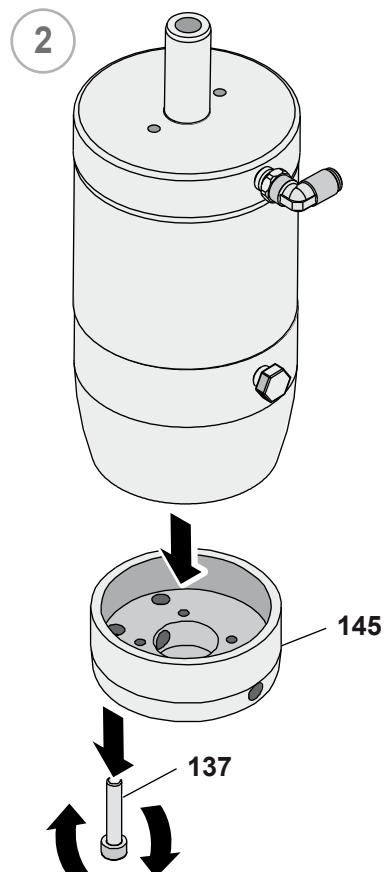
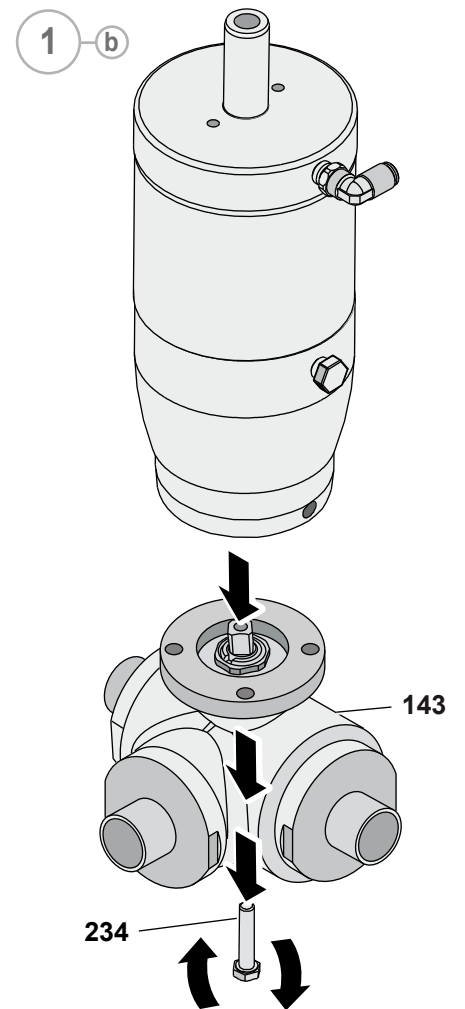
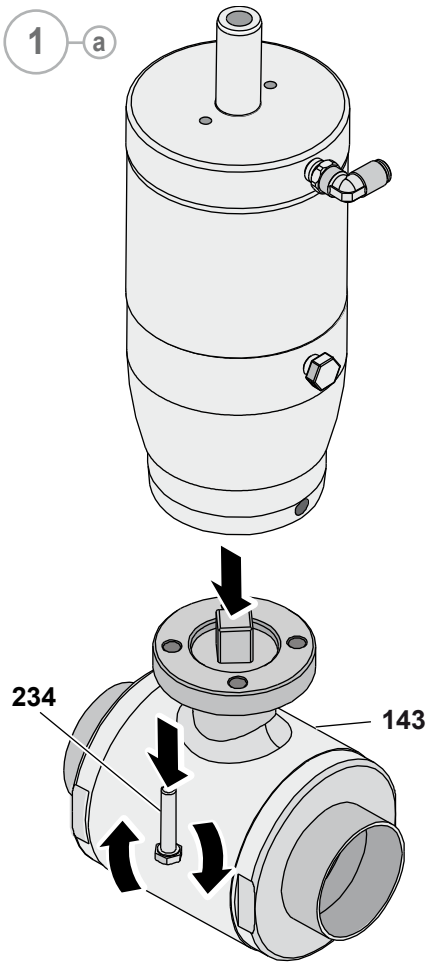

14 Assembly of the ZVS

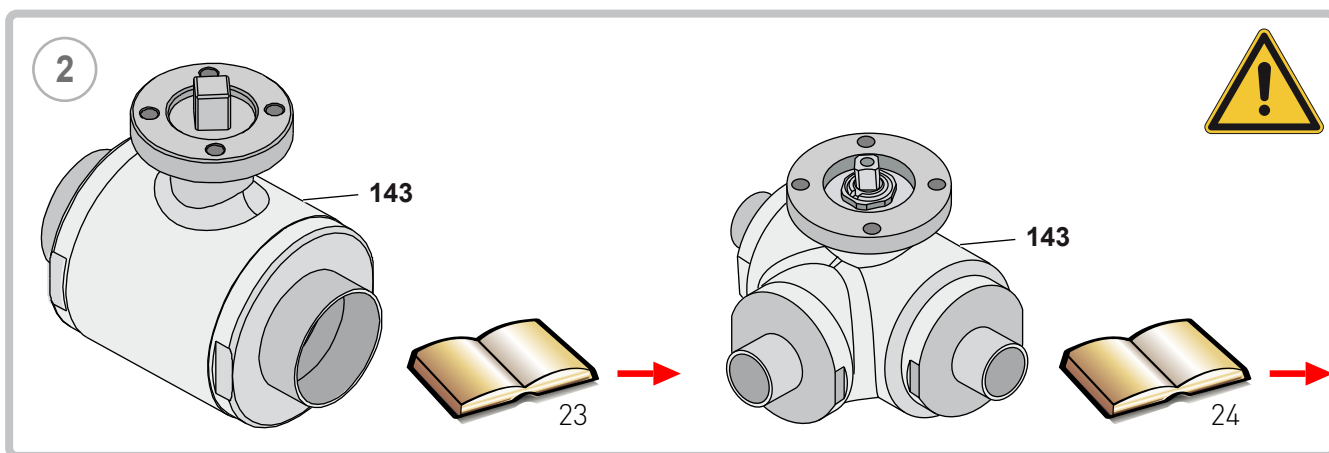
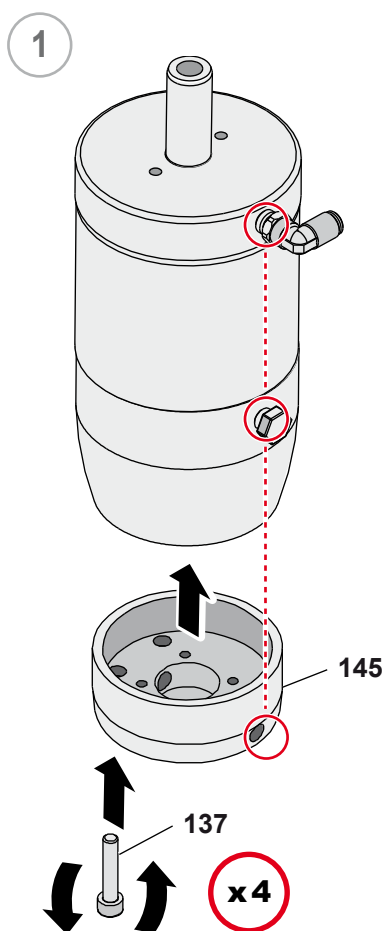

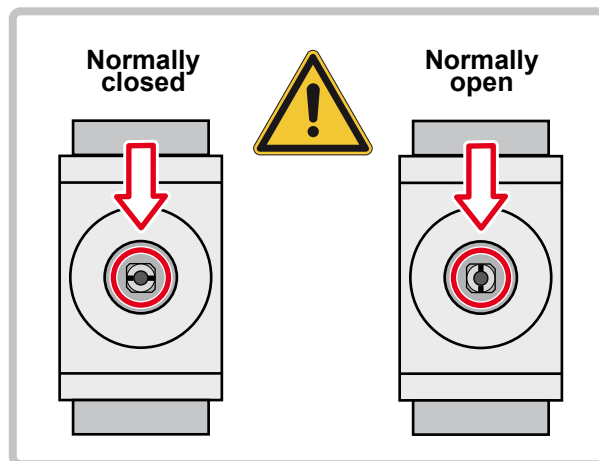
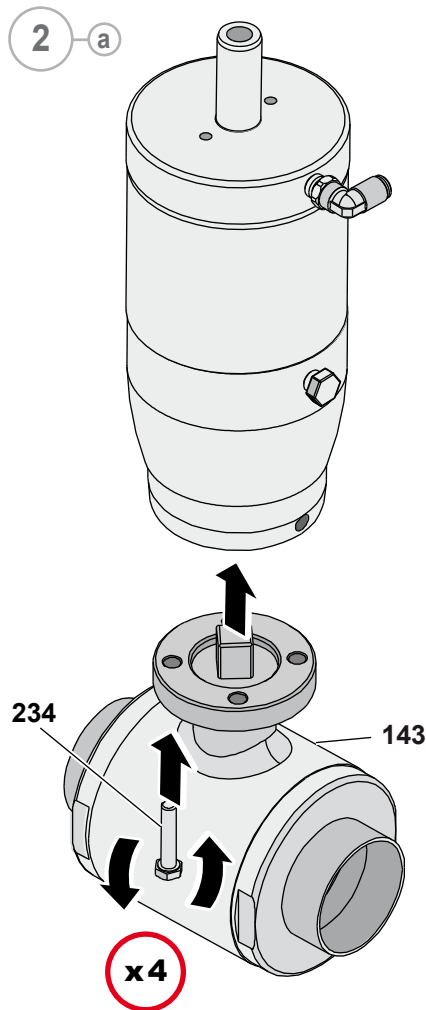

2 b

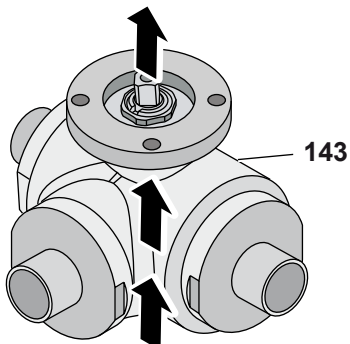
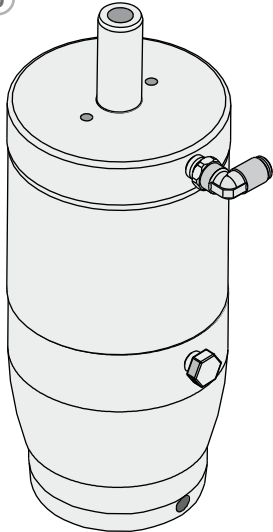

234

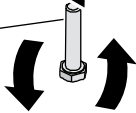

x4

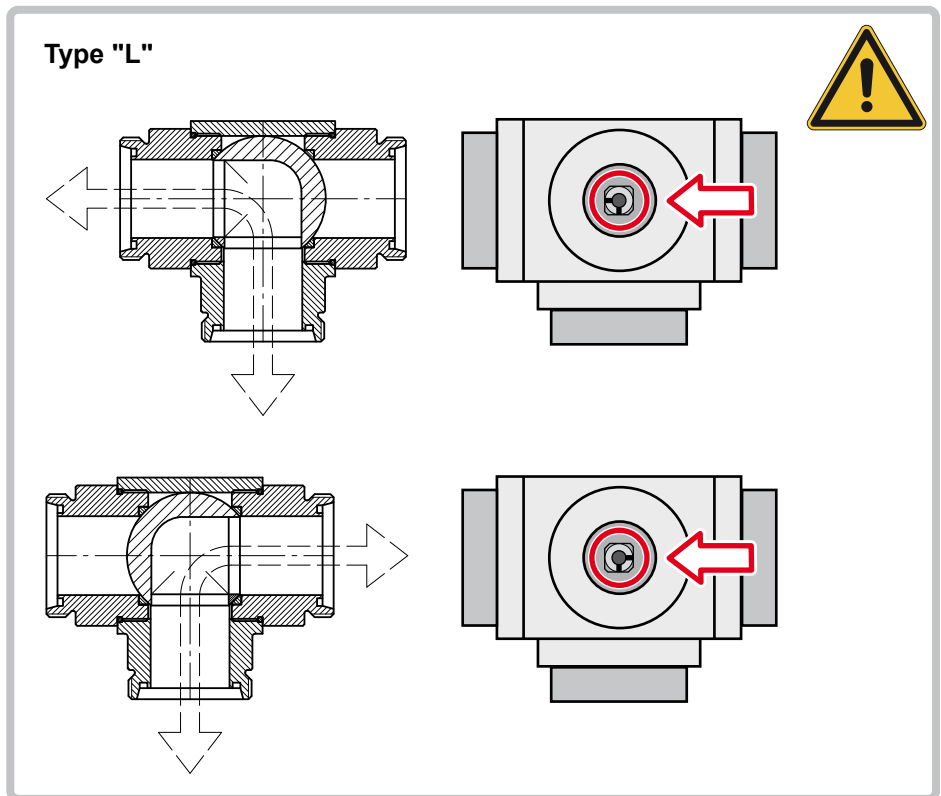

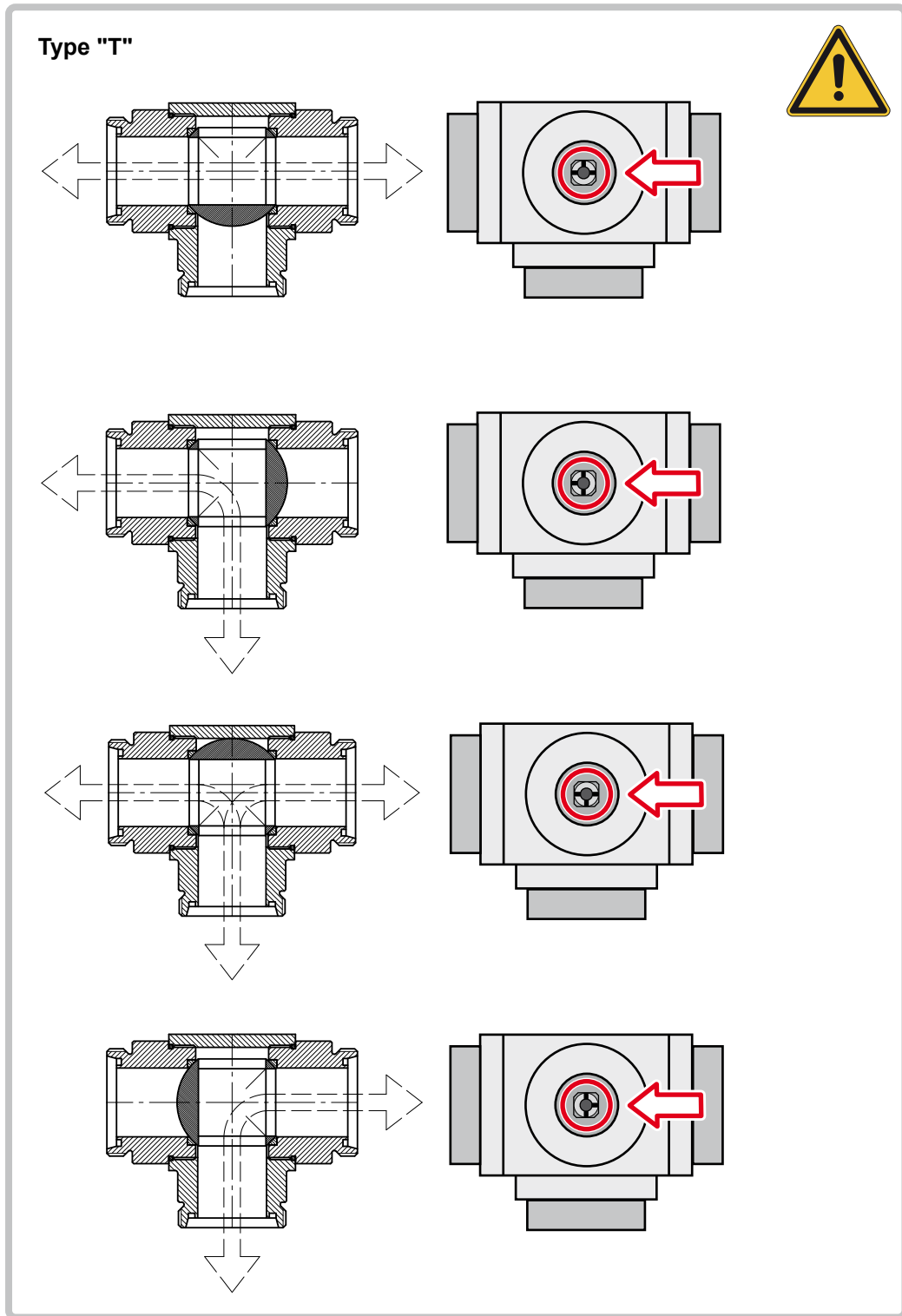

15 Annexes



GB - EC Declaration of conformity - A3-P-PRG-GB

EC DECLARATION OF CONFORMITY OF THE MACHINERY

(EC) 2006/42, Annex. II, p. 1 A

BARDIANI VALVOLE S.p.A.

Via G. di Vittorio 50/52 – 43045 Fornovo di Taro (Pr) – Italy

Declares

under its own responsibility that the machine:

Type:	PNEUMATIC VALVES
Model:	
Serial number:	
Function:	Fluid handling
Year of construction:	2016
Reference	

complies with all relevant provisions of the following EC directives:

(EC) 2006/42 MACHINERY

and also comply with the following EC Directives and Regulations:

(EU) 2014/30 ELECTROMAGNETIC COMPATIBILITY DIRECTIVE (EMC)

and the following harmonized standards, rules and / or technical specifications applied:

EN ISO 12100:2010

REGULATION (EC) 1935/2004 and subsequent amendments and additions with regard to steel and elastomers in contact with the product

REGULATION (EC) 10/2011 and subsequent amendments and additions with regard to PTFE in contact with the product

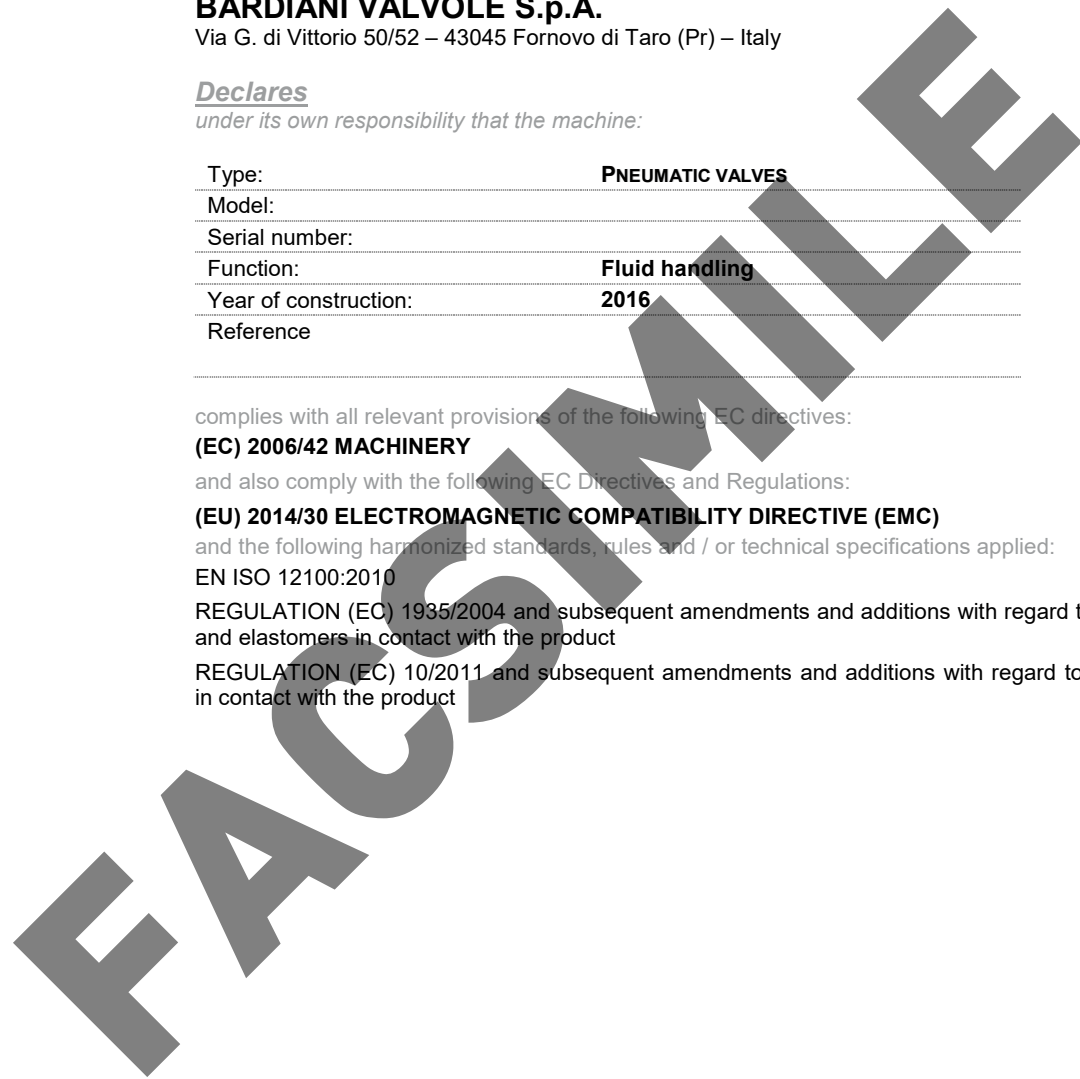

Fornovo di Taro
10/10/2016

Emanuela Bardiani
Legal representative

BARDIANI VALVOLE S.p.A.
Via G. di Vittorio 50/52
43045 Fornovo di Taro (Pr)

A3-P-PRG-GB Ed. 1. Rev. 0

162D diagram ZVS DN10--65

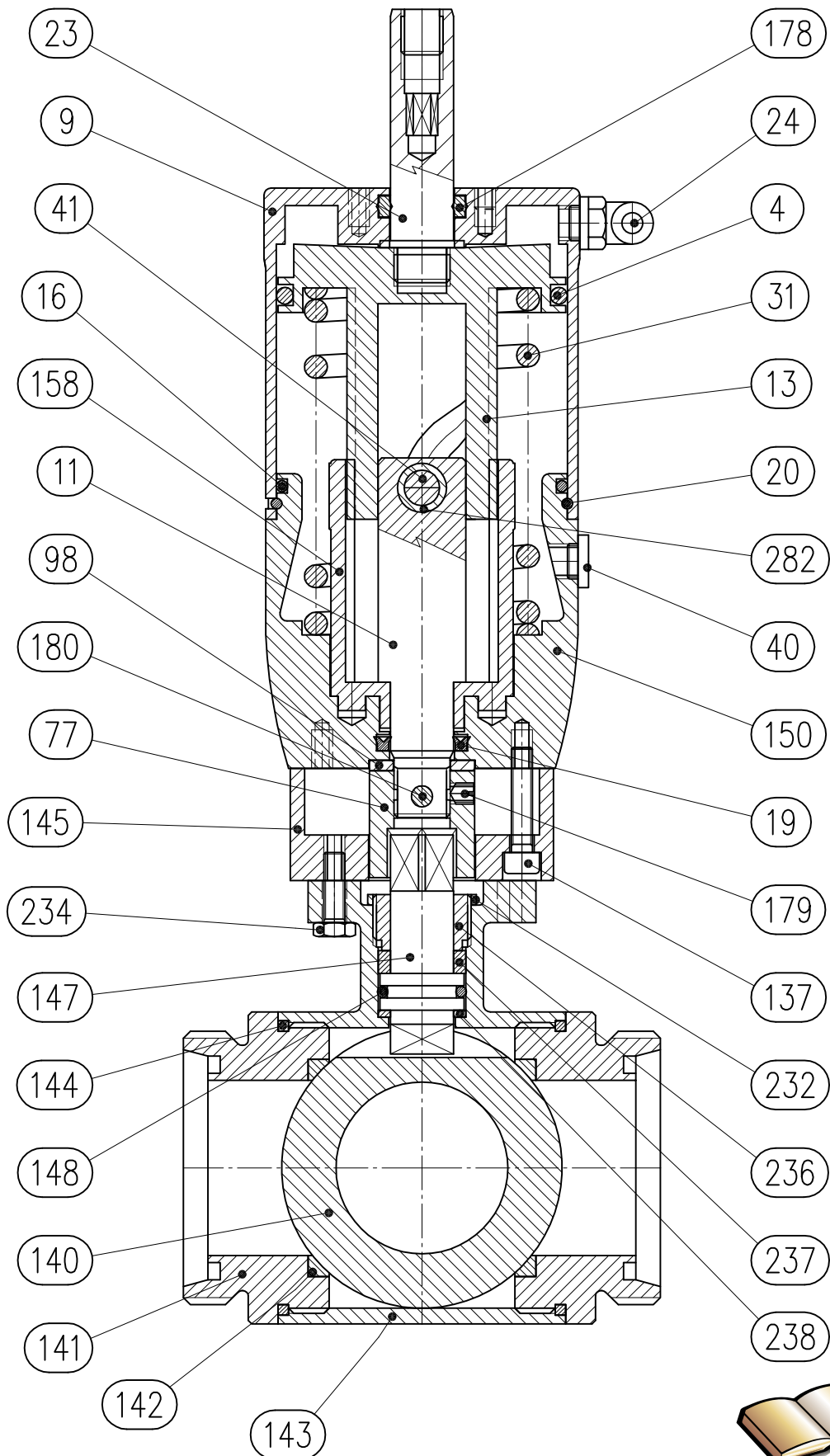

20

172D diagram ZVS DN65--100

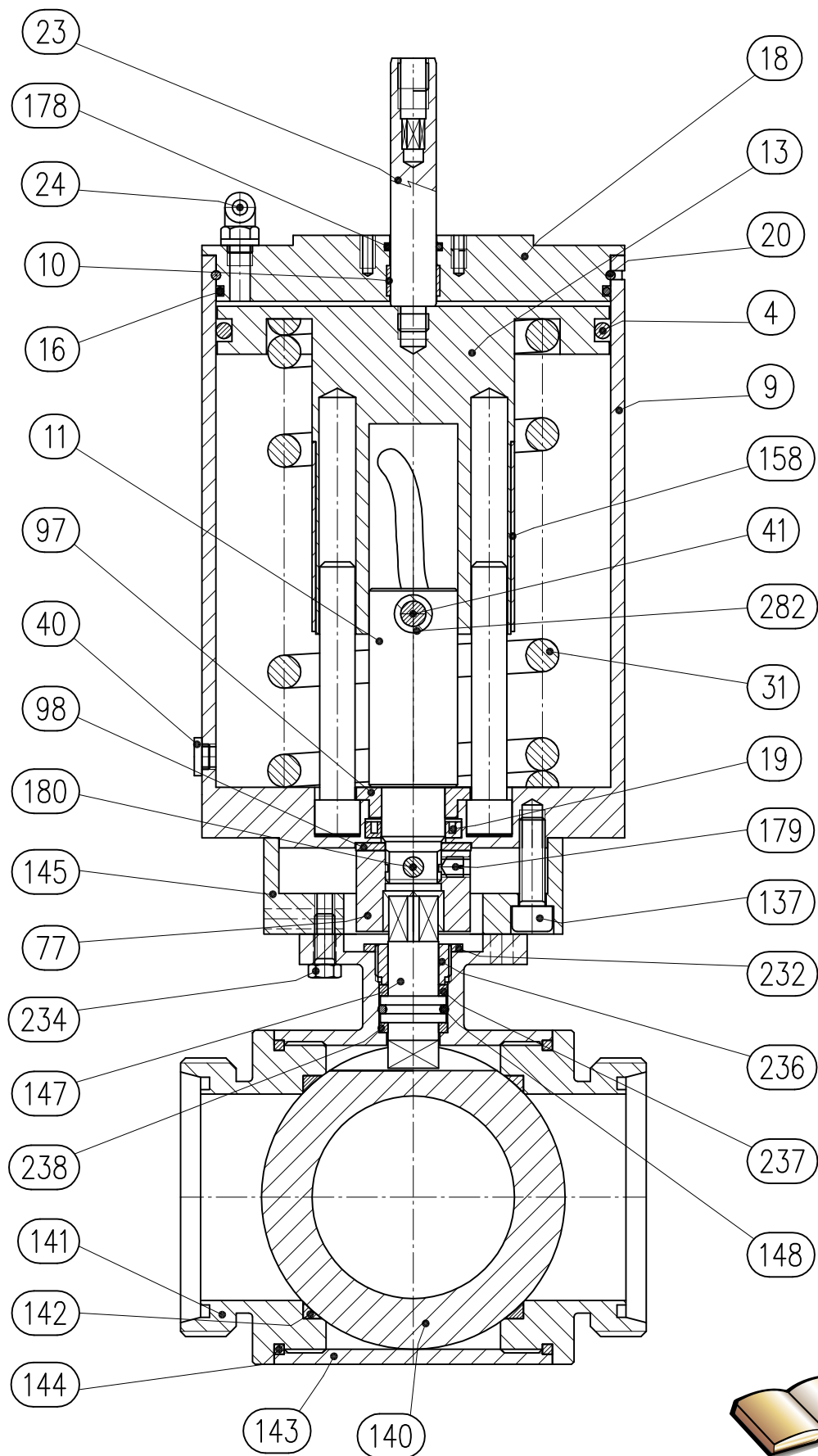

18 Warranty

1. VALIDITY

Bardiani Valvole's Products are manufactured in compliance with the technical specifications laid out in their "Instruction, Use and Maintenance Manual" and are fully compliant with the directives specifically mentioned in these manuals.

Bardiani Valvole S.p.A. guarantees its own Products against any design and/or construction and/or material defects and/or faults for a period of 12 (twelve) months from the date of delivery.

Notification of any Product defects and/or faults must be sent in writing to Bardiani Valvole S.p.A. within 8 (eight) days from their detection, providing adequate documentation of the defect/fault encountered as evidence.

Services provided in the warranty period shall not result in an extension of the warranty beyond the stipulated 12 (twelve)-month period, as this warranty validity period is to be considered mandatory.

2. CONTENTS OF THE WARRANTY

Notwithstanding and without prejudice to the rights of the Buyer, which may be acknowledged by applicable law, this warranty is to be intended as limited, at the discretion of Bardiani Valvole S.p.A., to the repair and/or replacement of the Product and/or part of the Product and/or its components which is/are found to be defective due to design and/or manufacturing and/or material faults.

In the event of repair and/or replacement of the Product and/or any one of its parts and/or components, any returned item/s shall become the property of Bardiani Valvole S.p.A. and the relative shipping costs shall be charged to Bardiani Valvole S.p.A.

Bardiani Valvole S.p.A., shall be under no obligation to compensate for any immaterial and/or indirect damages and shall in no way be held liable for consequential damages and/or losses, such as (by way of example only), damages due to loss of business, contracts, opportunities, time, production, profits, goodwill, image etc.

No retailer or distributor or dealer or agent or representative or employee or person appointed by Bardiani Valvole S.p.A. is authorized to make any amendments and/or integrations and/or extensions to this warranty.

3. WARRANTY EXCLUSIONS

- Elastomers and electrical components are expressly excluded from this warranty.
- This warranty does not cover design faults emerging whenever a Product is manufactured by Bardiani Valvole S.p.A. based on designs and/or technical specifications provided by the Buyer.
- Moreover this warranty excludes the following:
 - faults and/or defects resulting from incorrect and/or unsuitable and/or inadequate transportation of the Product;
 - faults and/or defects resulting from failure to comply with the indications laid out in the "Instruction, Use and Maintenance Manual" with regards to installation of the Product or in any event caused by incorrect and/or unsuitable and/or improper installation;
 - faults and/or defects resulting from failure to comply with indications laid out in the "Instruction, Use and Maintenance Manual" with regards to use and/or maintenance operations and/or storage of the Product or in any event caused by incorrect and/or unsuitable and/or improper use and/or maintenance operations and/or storage;
 - faults and/or defects due to normal wear and tear of the Product and/or its parts and/or its components;
 - faults and/or defects in the Product and/or its parts and/or its components for work and/or repairs being carried out by unskilled staff or staff that has not been authorised by Bardiani Valvole S.p.A.;
 - faults and/or defects in the Product and/or its parts and/or its components due to it/them being dropped and/or banged and/or dented and/or misused and/or tampering and/or breakage and/or accidents or in any event due to negligence and/or carelessness and/or neglect by the Buyer and in general for any causes not attributable to design and/or manufacturing and/or material defects;
 - faults and/or defects in the Product and/or its parts and/or its components caused by other events beyond the control of Bardiani Valvole S.p.A., such as force majeure or unforeseeable circumstances.

19 Recommendations

- 1.** Consultation of the "Instruction, Use and Maintenance Manual" is mandatory prior to the installation, use and maintenance of the products of all Products. All the information, indications, specifications, technical details provided herein are based on test data which the Manufacturer Bardiani Valvole S.p.A. holds to be reliable nevertheless the above is not deemed to be assumed as fully exhaustive inasmuch as not every possible use has been envisaged.
- 2.** All the illustrations and drawings provided are to be intended as indicative and therefore not binding, the illustrations being for presentation purposes only.
- 3.** It is the Buyer's duty to assess the suitability of the products for the use he intends to make of the same prior to placing the order as he/she will take the risks and accept liability in case of incorrect choice and use of the Products.
- 4.** The Manufacturer strongly recommends the Buyer to contact their sales team and request any information that might be needed in relation to the specifications and uses of the Products.
- 5.** The information provided in this manual refers to the standard products manufactured by Bardiani Valvole S.p.A. and therefore cannot be assumed to apply to customized products as well.
- 6.** Bardiani Valvole S.p.A. reserves the right to amend and/or integrate and/or update the data and/or information and/or technical details relative to Products at any time and without prior notice. Please visit the website www.bardiani.com, where the latest updated of the "Instruction, Use and Maintenance Manual" can be found".
- 7.** The content and validity of the warranty covering the Products of Bardiani Valvole S.p.A are dealt with in the relevant section in the "Instruction, Use and Maintenance Manual" which constitutes an integral part of the Products themselves.
- 8.** Bardiani Valvole S.p.A., shall not in any way be held liable for immaterial, indirect and consequential damages, such as (by way of example only), damages or loss of business, contracts, opportunities, time, production, profits, goodwill, image etc..

NOTES

Bardiani Valvole S.p.A.

via G. di Vittorio, 50/52 - 43045 Fornovo di Taro (PR) - Italy

tel. +39 0525 400044 - fax +39 0525 3408

bardiani@bardiani.com - www.bardiani.com