

Instruction, Use and Maintenance Manual



CONTROL UNITS
GIOTTO TOP®
ATEX

Bardiani Valvole S.p.A.

via G. di Vittorio, 50/52 - 43045 Fornovo di Taro (PR) - Italy

tel. +39 0525 - Fax 0525 3408

bardiani@bardiani.com - www.bardiani.com

MANUAL REVISION	DATE

INDEX

1	Safety, Warning and Mandatory Signs	5
2	General safety warnings	6
3	Instructions for safe use in explosion hazard areas	7
4	Technical data	12
5	Giotto Top® control unit for ATEX valves.	13
6	Disassembly / Assembly of the Giotto Top® for ATEX valves	14
7	Installation of the Giotto Top® for ATEX valves	17
8	Giotto Top® Pneumatic connections for ATEX valves.	19
9	Giotto Top® electrical connections for ATEX valves.	22
10	Troubleshooting	23
11	Maintenance and Cleaning	24
12	Declaration of conformity of valve complete with control unit containing at least one solenoid valve	25
13	Declaration of conformity of valve complete with control unit containing sensors only	26
14	Warranty	27
15	Recommendations	28

INTRODUCTION

This "Instruction, Use and Maintenance Manual" has been drawn up expressly for expert technical personnel. Consequently any information which can easily be deduced from reading the text and/or examining the illustrations and/or drawings provided herein shall not be the object of further explanation.

It forms an integral part of the Products supplied and must be read prior to any installation, operation and/or maintenance of all types of control unit provided.

This manual must be saved for future reference and be kept readily available at the unit.

The essential characteristics of all types of control unit described herein being consistent, the Manufacturer reserves the right to alter and or complement and or update at any time and with no obligation to notify so in writing, the data and or information relevant to the use of the control unit described in this "Instruction, Use and Maintenance Manual".

A constantly updated version of this "Instruction, Use and Maintenance Manual" is available at the Manufacturer's website www.bardianivalvole.it.

Under no circumstance shall the Manufacturer be held liable for consequences resulting from failure and or improper use of the instructions contained in this Manual and relating to the installation, operating, maintenance and storage of the products.

All rights reserved.

Full or part reproduction, transfer and or recording of any part of this "Instruction, Use and Maintenance Manual" by all means, whether it be electronic, on hard copy, mechanical or any other means or recording or reuse is strictly prohibited without the prior written consent of the Manufacturer and for any use other than that of the Buyer.

(Translation of the Original Instructions in the italian Language)

1 Safety, Warning and Mandatory Signs

SIGNALS		
Pictogram	Description	Notes
	CAUTION General	This tells the person in question that the operation described involves (when not performed in accordance with the relative safety regulations) the risk of personal injury.
	OBLIGATION General	Special instructions must be followed to avoid injury to persons.
	SKILLED PERSONNEL	Dismantling/Assembling and maintenance operations must be carried out by expert technicians only.
	NOTE	Follow the indicated note with care
	ELECTRICAL CONNECTION	Electrical connection to the control unit
	ELECTRICAL DISCONNECTION	Electrical disconnection from the control unit
	PNEUMATIC CONNECTION	Compressed air connection to the control unit
	PNEUMATIC DISCONNECTION	Compressed air disconnection from the control unit.

2 General safety warnings

The Giotto Top® control unit for ATEX valves has been designed to control the pneumatically operated process valves for ATEX valves manufactured by Bardiani Valvole S.p.A.. It is possible to equip the Giotto Top® for ATEX valves with:

- a maximum of three inductive sensors for controlling the position and up to a maximum of two solenoid valves for controlling the process valve
- a maximum of 2 inductive sensors for controlling the position and up to a maximum of three solenoid valves for controlling the process valve.

For the electrical connections inside the control unit, there is a terminal board.

For entry of the cable into the control unit there are two different configurations:

- threaded cable gland PG11 (for cables with a diameter of between 4 - 10.5 mm)
- threaded cable gland M20x1.5 (for cables with a diameter of between 5 - 12.5mm).

General warnings

- Always read the technical data carefully before machine installation, operation and maintenance.
- The Giotto Top® for ATEX valves must always be installed, operated and maintained by authorized personnel. Said personnel must know and understand both the unit and the contents of the manual.
- Take care over any separate parts of the Giotto Top® for ATEX valves when removing it from its packaging.
- Always connect the air supply carefully and disconnect it after use.
- Always connect the power supply carefully and disconnect it after use.
- Never touch the moving parts in the Giotto Top® for ATEX valves or in the valves.
- Always handle detergents with care.



Prohibited use

Use of the control unit is not envisaged:

- for any operations other than those for which it was designed.

3 Instructions for safe use in explosion hazard areas

Use in compliance with Directive 2014/34/EC

Use in explosion hazard zones in compliance with classification:

Control unit assembly without solenoid valve installed on Baridani valve certified in accordance with Directive 2014/34/EC

Group II, category 2 G c Ex ia II TX
Group II, category 2 D c Ex ia III TX



It is forbidden to use the control unit in this configuration in explosion and/or fire hazard areas classified as Zone 0 and 20.

Control unit assembly with solenoid valve installed on Baridani valve certified in accordance with Directive 2014/34/EC

Group II, category 2 G c Ex ia II TX



It is forbidden to use the control unit in this configuration in explosion and/or fire hazard areas classified as Zone 0, 20, 21, 22.

TX = The temperature class depends on the temperature of the working fluid

Filed with the Notified Body:

TUV IT 07 ATEX 010 AR Rev.002



The end user is responsible for assessing the risk of explosion and classification of the unit and zone of application in accordance with Directive 1999/92/EC.



The system on which the valve is installed must be earthed in accordance with the regulations in force.



The control unit and its components must be assembled, connected and put into service by expert personnel only.
 The expert personnel must have adequate knowledge of types of explosion protection, standards and regulations for means of production in explosion hazard zones.



All maintenance, assembling and installation operations must be carried out in a potentially non-explosive atmosphere.



Make sure, based on its classification, that the control unit and its components are suitable for the application in question.



The internal electrical components which can be installed in the J-Giotto Top® for ATEX valves must be selected based on the classification of the group and the zone in which the control unit will be used.

Component	ATEX Certified	Category
Sensor	PTB 01 ATEX 2191	II 1G Ex ia IIB T6 Ga II 2G EX ia IIC T6 Gb II 1D Ex ia IIIC T90°C Da
Solenoid valve	PTB 07 ATEX 2048	II 2G Ex ia IIC T6 Gb



Connect the electrical components of the control unit to intrinsically safe circuits only. For further information on the components, it is mandatory to consult the relative manuals.

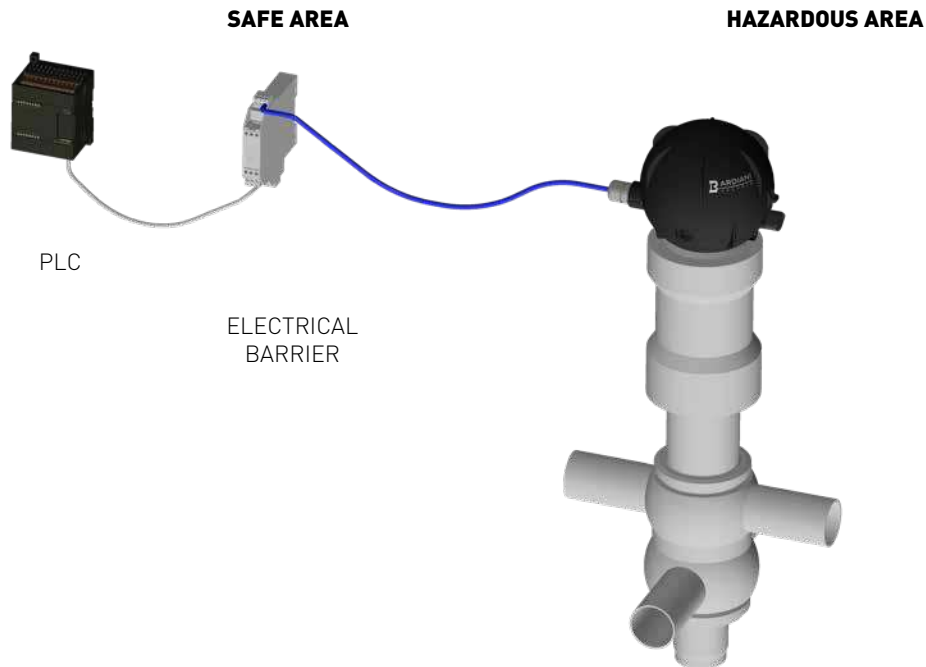

The operating conditions of the electrical components in the control unit are indicated in the following pdf documents attached to this manual.

Description	File name
Sensor manual (English)	80231773UK
CE certificate, sensor	8002078
EC type-examination, sensor (1D)	BVS04ATEXE153
EC type-examination, sensor (1G)	PTB01ATEX2191
Solenoid valve manual (German)	MA6144-Manual-DE-DE 1512 04
Solenoid valve manual (English)	MA6144-Manual-EU-ML 1512 04
CE certificate, solenoid valve	SOLENOID VALVE Burkert 6510 ATEX certificate
EC type-examination, solenoid valve	6144_Exi_PTB07ATEX2048-1-2_en



Permitted ambient temperature in the place of use: -10°C...+40°C.



The temperature of the outer surfaces of the valve also depends on the fluid which flows through it.



Installation and assembly instructions:

- abide by the relative directives and regulations in force
- protect the J-Giotto Top® control units for ATEX valves and the cables from damage.



In the event of dropping/hitting the valve, it is compulsory to check correct operation as any friction caused by component deformation may cause malfunctions and sources of ignition.



The control unit must be installed away from systems and/or places which generate stray electric currents.



Mechanical damage, in most cases, results in blocked operation; consequently there are no direct risks of ignition.



Lightning protection measures and protection against currents caused by lightning in nearby areas are required.



The control unit must not be exposed to direct sunlight.



During assembly take care to ensure foreign bodies are not left inside the control unit.



During assembly take care to prevent the formation of sparks caused by rubbing oxidizable substances such as iron or steel.



Keep the control unit clear of any potentially explosive dust deposits. Do not allow dust to build up to over 5 mm in depth.



If the valve on which the control unit is installed operates with potentially explosive products, the end user must classify the operating areas in accordance with ATEX Directive 199/92/EC as any valve emissions may create a potentially explosive atmosphere.



Consult the attached use and maintenance manuals.

4 Technical data

CONTROL UNIT TECHNICAL DATA	
Weight	from 0.55 Kg to 0.65 Kg depending on the configuration
Casing material	PA6 GF30 dissipative
Gaskets material	NBR
Protection class	IP67
Air supply and vent connections	1/8" BSP
Air line connections	6 mm / 1/4" (ON REQUEST)
Electrical connections	Cable gland PG11 or M20x1.5
Field bus connections	
Vibrations	1mm amplitude f=10..55Hz
Storage temperature	-25..+70°C
Operating temperature	-10...+50°C
Air supply	Class 2,4,3 according to ISO 8573-1

SOLENOID VALVE APPLICATION CRITERIA	
Single Acting Valves	1 Solenoid valve
Double Acting Valves (1 normally open and 1 normally closed), Mixproof and Twin-Stop valves (2 normally closed)	2 Solenoid valves
Mixproof valves with air supply for opening, top and bottom lift (3 normally closed)	3 Solenoid valves

SOLENOID VALVE TECHNICAL DATA
See the attached instruction manuals

INDUCTIVE SENSOR TECHNICAL DATA
See the attached instruction manuals

In the event of any doubt, please contact Bardiani Valvole S.p.A.

5 Giotto Top® control unit for ATEX valves.

NO.	DESCRIPTION
21	Base
21a	Sealing ring
21b	Sealing ring
21d	Double guide
21e	Vent plug
21f	Air coupling
21g	Air coupling
21i	Cap
21k	Terminal block with support
22	Cam
25	Screw
26	Bardiani case
27a	Sensor
27d	Micro-size inductive sensors holder slide
114a	Sleeve with cable gland PG11
114b	Sleeve with cable gland M20x1.5
192	Solenoid valve
192b	Solenoid valve support
192c	Cap
192d	Solenoid valve board
192e	Sealing ring

6 Disassembly / Assembly of the Giotto Top® for ATEX valves

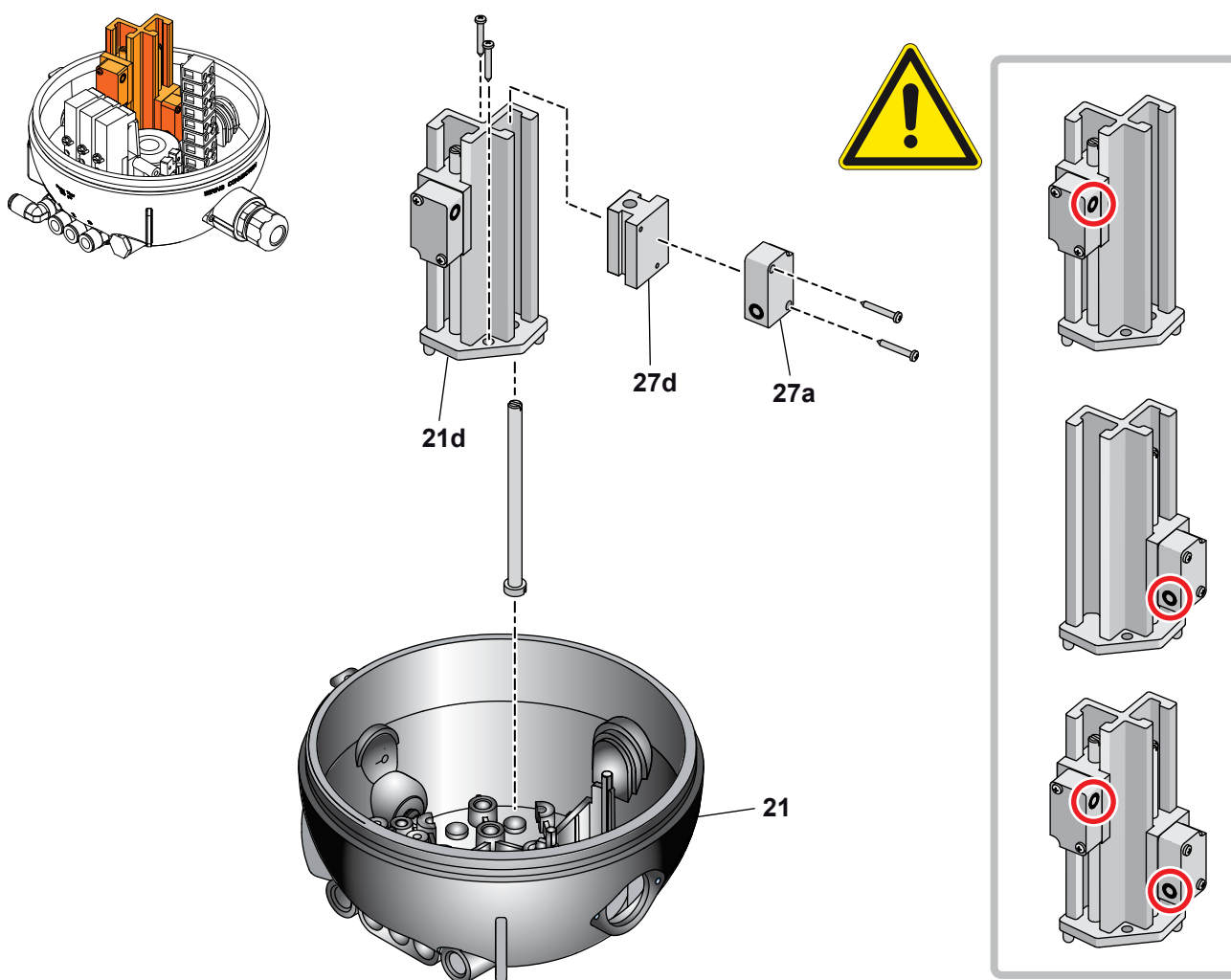
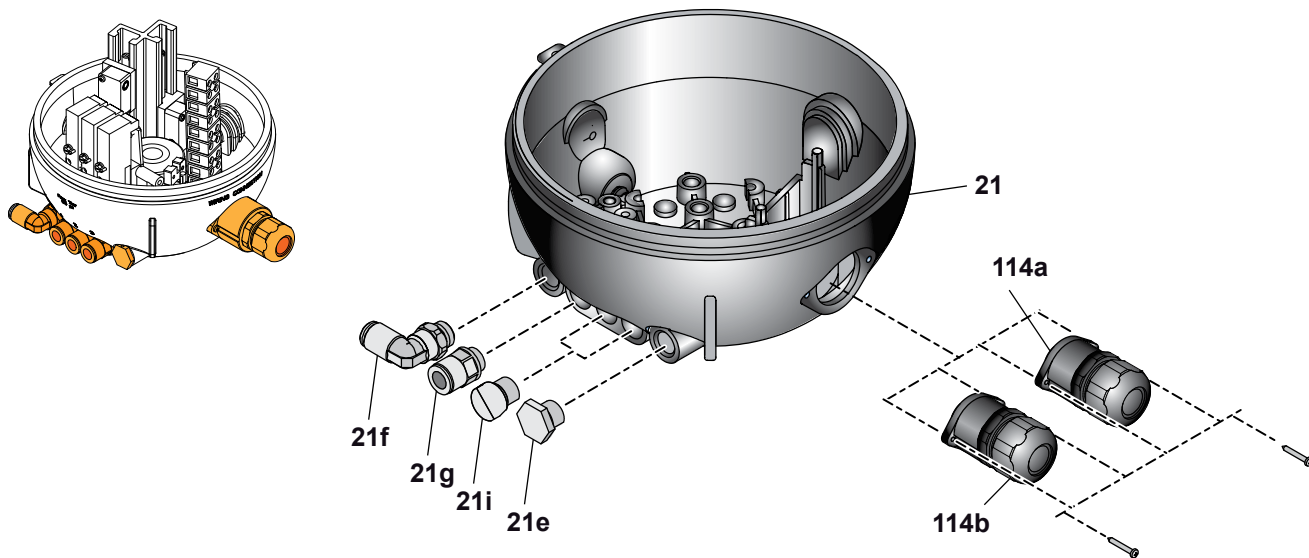

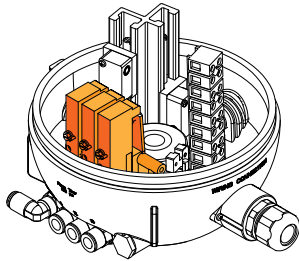

TYPE 8

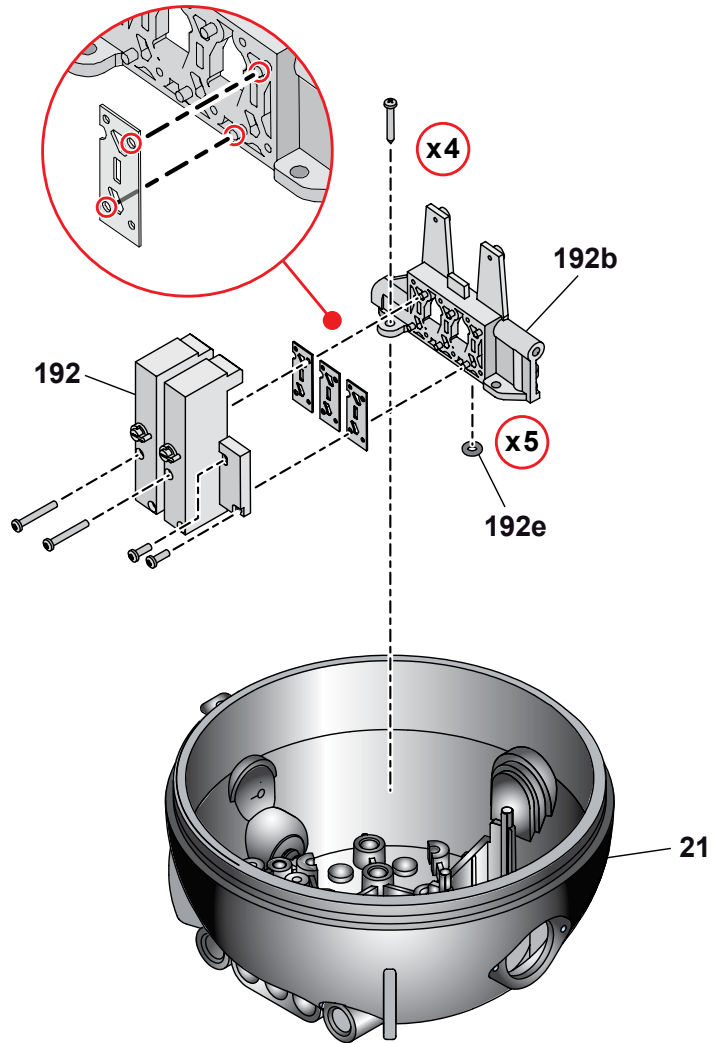

Solenoid valve sequence

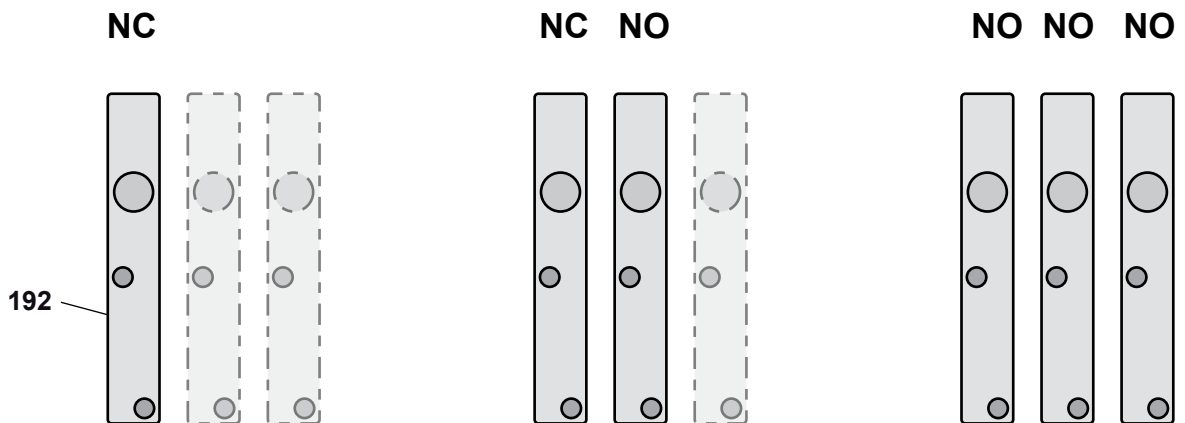

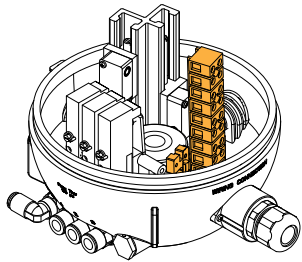

TYPE B - TYPE S

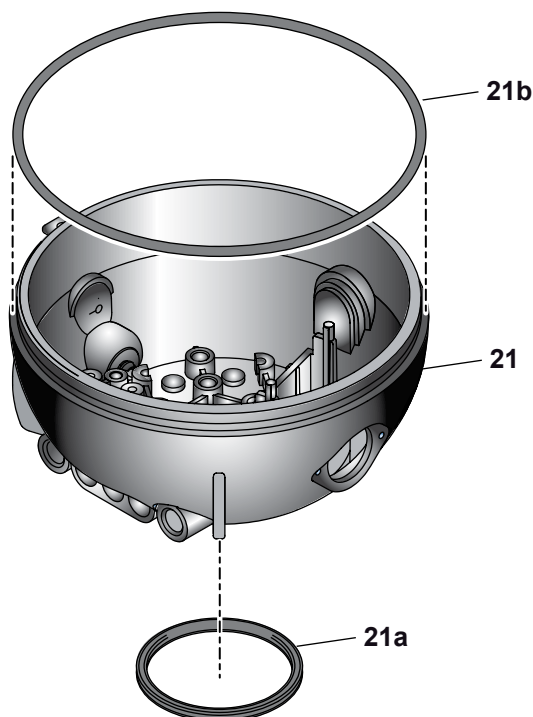
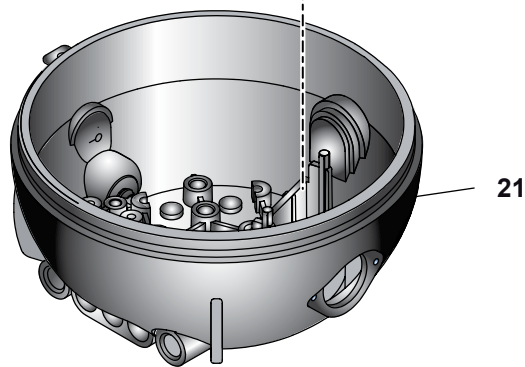
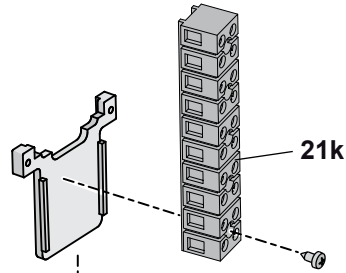

7 Installation of the Giotto Top® for ATEX valves

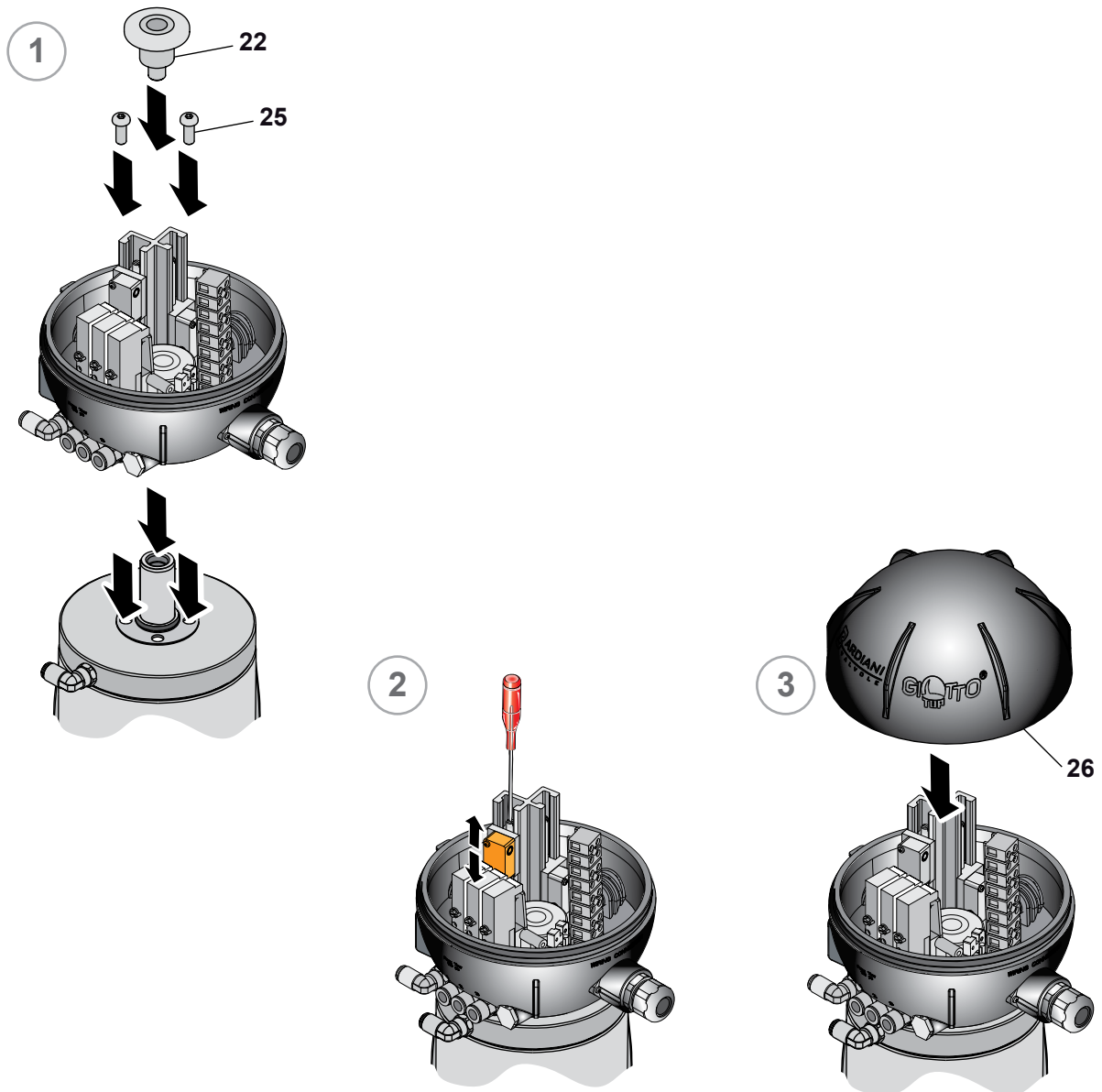

WARNING

Always make sure that all wires are connected and securely fastened to the terminals and that the solenoid valves, solenoid valves support, terminal block and any other parts inside the J-Giotto Top® for ATEX valves are well assembled and secured.



WARNING

Always make sure that the electrical and pneumatic connections are disconnected when carrying out operations on the Giotto Top® for ATEX valves.

External inductive sensor installation

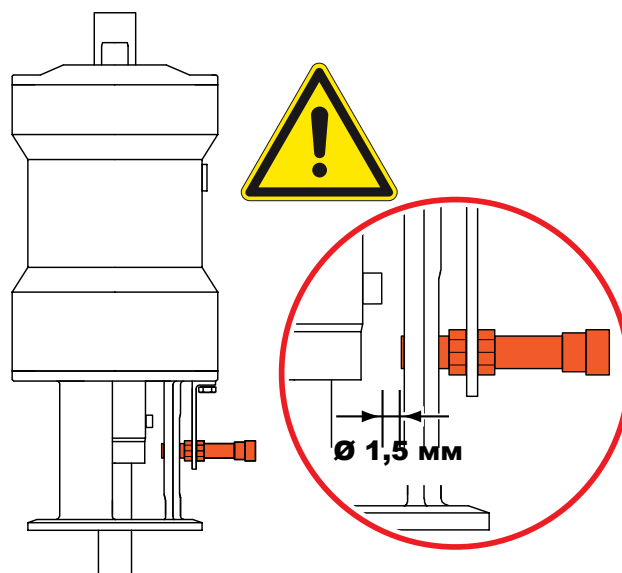
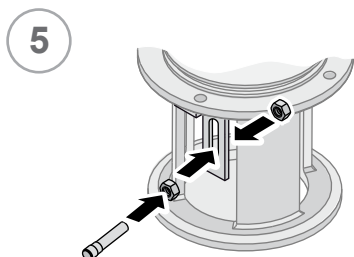
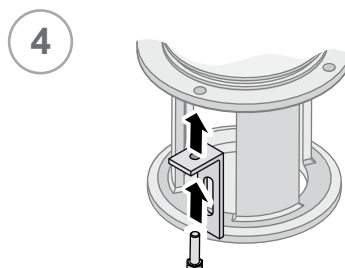
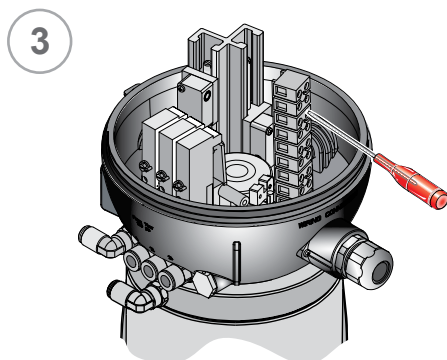
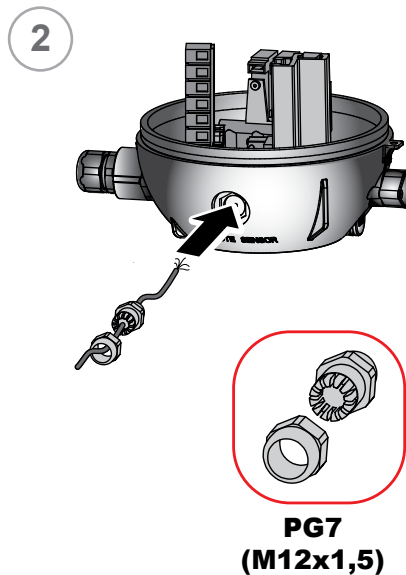
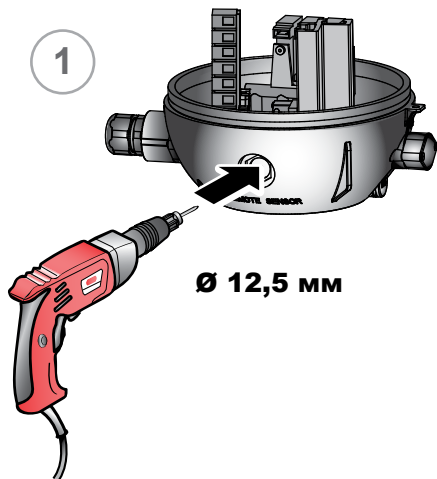

8 Giotto Top® Pneumatic connections for ATEX valves.

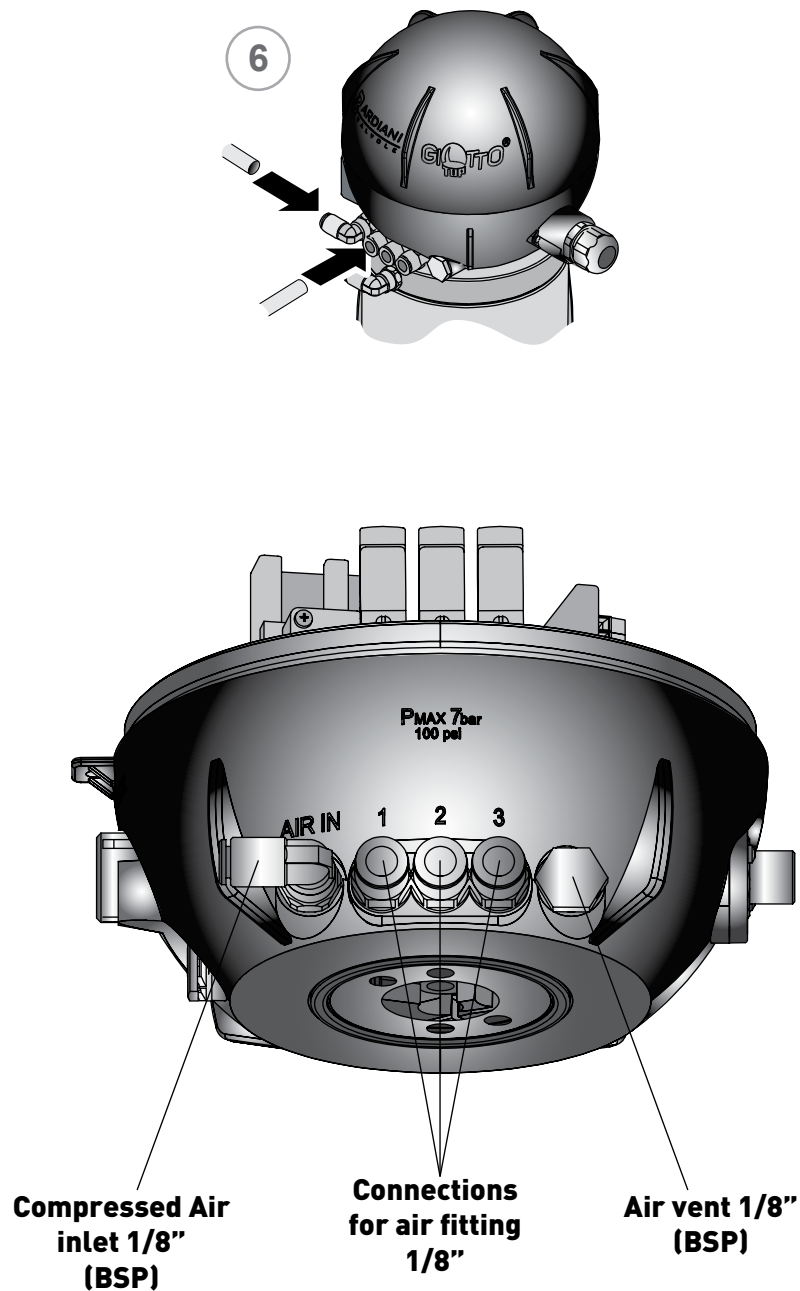

WARNING

Use only pipes with an **external diameter of 6 mm.**

Cut these pipes with a suitable cutter to avoid damaging the pipe which could lead to Giotto Top® ATEX valves malfunctions.

Select a suitable length of pipe which allows the Giotto Top® for ATEX valves to be removed without unscrewing the anchoring.

Valve with single acting actuator

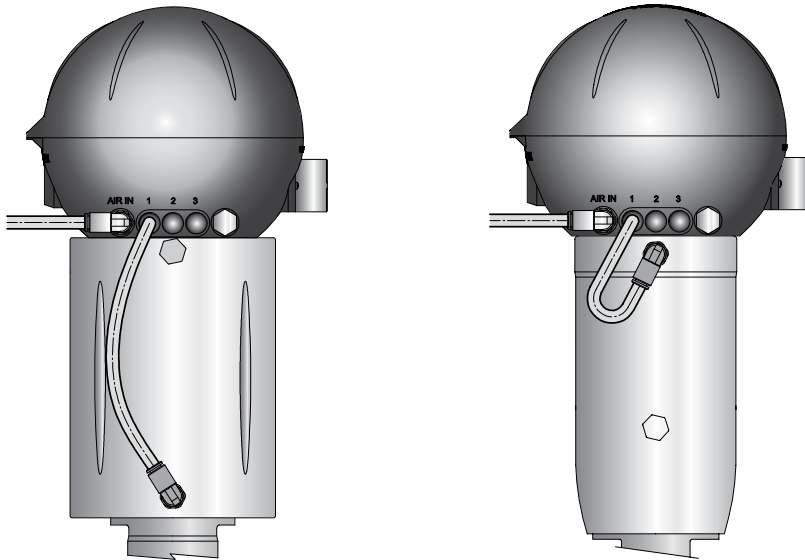

Valve with double acting actuator

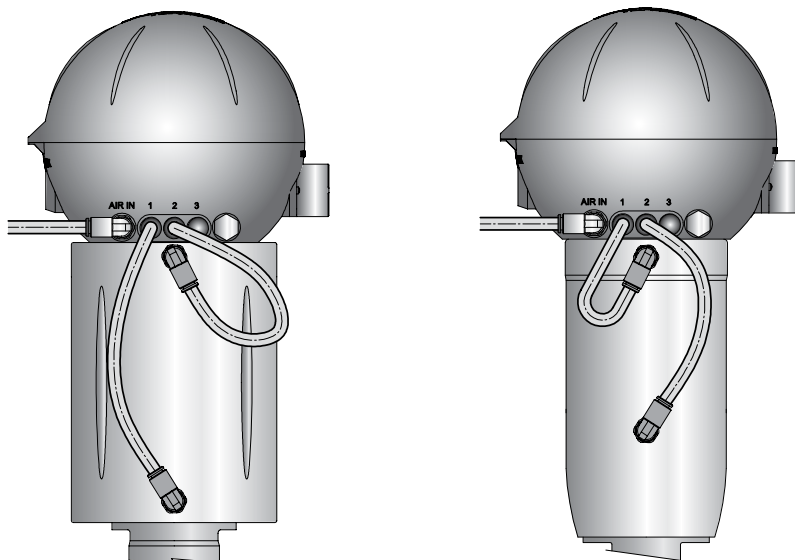

Valve with single acting actuator with Twin Stop

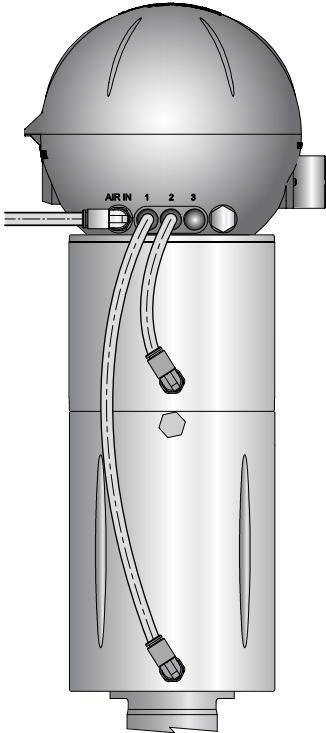

Mixproof valve

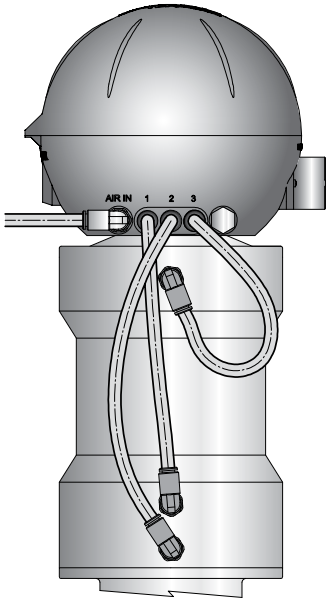

9 Giotto Top® electrical connections for ATEX valves.

2 ATEX sensors with 3 ATEX normally closed solenoid valves

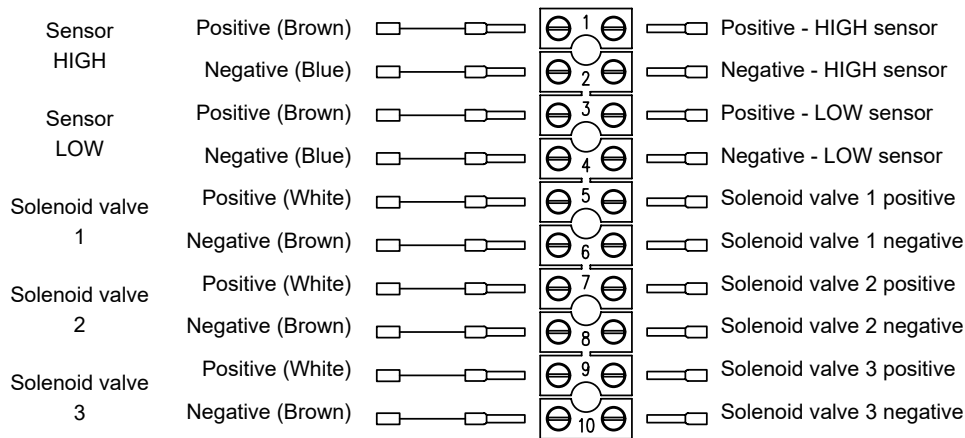

2 ATEX sensors with 1 ATEX normally closed solenoid valve

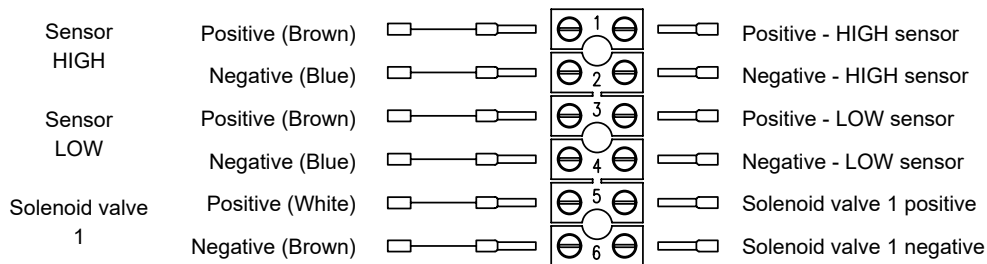

2 ATEX sensors with 2 ATEX solenoid valves (1 N.C. + 1 N.C.)

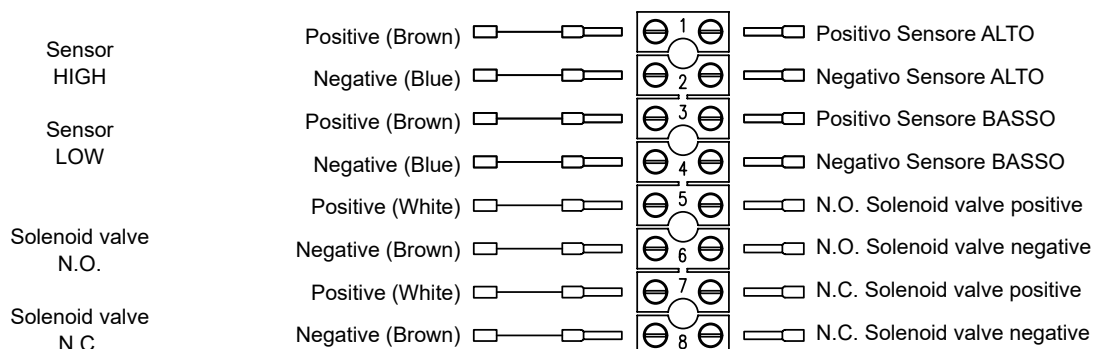

2 ATEX sensors with 2 ATEX normally closed solenoid valves

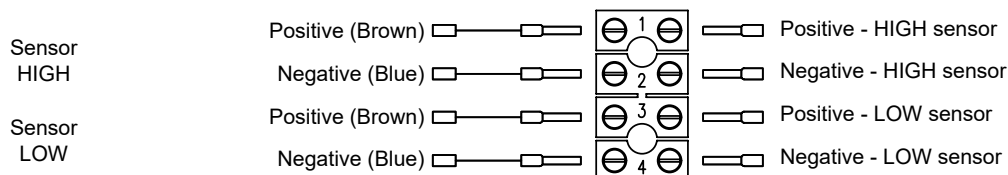

10 Troubleshooting



PROBLEM	POSSIBLE CAUSE	POSSIBLE SOLUTION
Air leak from solenoid valve support	No gaskets or loose fitting	Check the sealing capacity of the gaskets and tighten the screws
Air leaks in safety valve		
The solenoid valve does not activate	Damaged solenoid valve	Replace solenoid valve
	Circuit board damaged	Replace the circuit board
	Air supply pressure incorrect	Consult the Technical Data section in the Manual
	Solenoid valve support damaged	Replace solenoid valve support
	Electrical connections not made properly	Check the connections in the terminal block on the electrical board and tighten the screws.
The inductive sensors are not working	Inductive sensors damaged	Replace inductive sensors
	Electrical connections not made properly	Check the connections in the terminal block on the electrical board and tighten the screws.
	Distance between the cam and the inductive sensors greater than 1.5 mm.	Check the centring of the Giotto and the fastening to the double guide

11 Maintenance and Cleaning

When used correctly the Giotto Top® for ATEX valves does not need any special maintenance. Any repair work must be carried out by authorized personnel only, making sure that the electrical and pneumatic power supplies have been disconnected before carrying out any operation inside the Giotto Top®.



WARNING

Before using cleaning products make sure they are compatible with the materials used to construct the Giotto Top® for ATEX valves, both the casing and the gaskets.

If solvents or cleaning agents containing acids or alkaline substances are used, always make sure the Giotto Top® for ATEX valves is immediately rinsed with clean water.

When so doing, pay particular attention to those areas where there are orifices or openings.



WARNING

Each time the casing is open, make sure that the various cables inside it are repositioned where they do not interfere with cam movement.



WARNING

Should it be necessary to replace any component of the Giotto Top® for ATEX valves, contact Bardiani Valvole S.p.A. to purchase the necessary spare part as the use of any products not supplied by us may compromise correct valve operation or constitute a hazard for personnel.

12 Declaration of conformity of valve complete with control unit containing at least one solenoid valve



EC Declaration of Conformity -
Atex

EC DECLARATION OF CONFORMITY OF THE MACHINERY

(EC) 2006/42, Annex. II, p. 1, let. A
(EU) 2014/34, Annex. X

BARDIANI VALVOLE S.p.A.

Via G. di Vittorio 50/52 – 43045 Fornovo di Taro (Pr) – Italia

Declares

under its own responsibility that the machine:

Type:	Pneumatic valves
Model:	
Serial number:	
Function:	Fluid handling
Year of construction:	2017
Tech. Ref. File	949-01-00
Deposited on N.B.	TUV IT 07 ATEX 010 AR Rev.002
Reference	

complies with all relevant provisions of the following EC directives:

(EC) 2006/42 MACHINERY

(EU) 2014/34 ATEX

and also comply with the following EC Directives and Regulations:

(EU) 2014/30 ELECTROMAGNETIC COMPATIBILITY DIRECTIVE (EMC)

and the following harmonized standards, rules and / or technical specifications applied:

EN ISO 12100:2010

REGULATION (EC) 1935/2004/EC and subsequent amendments and additions with regard to steel and elastomers in contact with the product

REGULATION (EC) 10/2011 and subsequent amendments and additions with regard to PTFE in contact with the product

EN 1127-1:2011

EN ISO 80079-36

EN ISO 80079-37

EN 60079-0:2012

EN 60079-11:2012

The equipment is classified as follows:



Group II, Category 2 G c Ex ia IIB TX

TX = The temperature class dependent on the temperature of the working medium.

Fornovo di Taro

26.07.2018

Emanuela Bardiani
Legal Representative

13 Declaration of conformity of valve complete with control unit containing sensors only



EC Declaration of Conformity - ATEX

EC DECLARATION OF CONFORMITY OF THE MACHINERY

(EC) 2006/42, Annex. II, p. 1, let. A
(EU) 2014/34, Annex. X

BARDIANI VALVOLE S.p.A.

Via G. di Vittorio 50/52 – 43045 Fornovo di Taro (Pr) – Italia

Declares

under its own responsibility that the machine:

Type:	Pneumatic valves
Model:	
Serial number:	
Function:	Fluid handling
Year of construction:	2017
Tech. Ref. File	949-01-00
Deposited on N.B.	TUV IT 07 ATEX 010 AR Rev.002
Reference	

complies with all relevant provisions of the following EC directives:

(EC) 2006/42 MACHINERY

(EU) 2014/34 ATEX

and also comply with the following EC Directives and Regulations:

(EU) 2014/30 ELECTROMAGNETIC COMPATIBILITY DIRECTIVE (EMC)

and the following harmonized standards, rules and / or technical specifications applied:

EN ISO 12100:2010

REGULATION (EC) 1935/2004/EC and subsequent amendments and additions with regard to steel and elastomers in contact with the product

REGULATION (EC) 10/2011 and subsequent amendments and additions with regard to PTFE in contact with the product

EN 1127-1:2011

EN ISO 80079-36

EN ISO 80079-37

EN 60079-0:2012

EN 60079-11:2012

The equipment is classified as follows:



Group II, Category 2 G c Ex ia IIB TX

Group II, Category 2 D c Ex ia IIIC TX

TX = The temperature class dependent on the temperature of the working medium.

Fornovo di Taro

26.07.2018

Emanuela Bardiani
Legal Representative

BARDIANI VALVOLE S.p.A.
Via G. di Vittorio 50/52
43045 Fornovo di Taro (Pr)

14 Warranty

1. VALIDITY

Bardiani Valvole's Products are manufactured in compliance with the technical specifications laid out in their "Instruction, Use and Maintenance Manual" and are fully compliant with the directives specifically mentioned in these manuals.

Bardiani Valvole S.p.A. guarantees its own Products against any design and/or construction and/or material defects and/or faults for a period of 12 (twelve) months from the date of delivery.

Notification of any Product defects and/or faults must be sent in writing to Bardiani Valvole S.p.A. within 8 (eight) days from their detection, providing adequate documentation of the defect/fault encountered as evidence.

Services provided in the warranty period shall not result in an extension of the warranty beyond the stipulated 12 (twelve)-month period, as this warranty validity period is to be considered mandatory.

2. CONTENTS OF THE WARRANTY

Notwithstanding and without prejudice to the rights of the Buyer, which may be acknowledged by applicable law, this warranty is to be intended as limited, at the discretion of Bardiani Valvole S.p.A., to the repair and/or replacement of the Product and/or part of the Product and/or its components which is/are found to be defective due to design and/or manufacturing and/or material faults.

In the event of repair and/or replacement of the Product and/or any one of its parts and/or components, any returned item/s shall become the property of Bardiani Valvole S.p.A. and the relative shipping costs shall be charged to Bardiani Valvole S.p.A.

Bardiani Valvole S.p.A., shall be under no obligation to compensate for any immaterial and/or indirect damages and shall in no way be held liable for consequential damages and/or losses, such as (by way of example only), damages due to loss of business, contracts, opportunities, time, production, profits, goodwill, image etc.

No retailer or distributor or dealer or agent or representative or employee or person appointed by Bardiani Valvole S.p.A. is authorized to make any amendments and/or integrations and/or extensions to this warranty.

3. WARRANTY EXCLUSIONS

- Elastomers and electrical components are expressly excluded from this warranty.
- This warranty does not cover design faults emerging whenever a Product is manufactured by Bardiani Valvole S.p.A. based on designs and/or technical specifications provided by the Buyer.
- Moreover this warranty excludes the following:
 - faults and/or defects resulting from incorrect and/or unsuitable and/or inadequate transportation of the Product;
 - faults and/or defects resulting from failure to comply with the indications laid out in the "Instruction, Use and Maintenance Manual" with regards to installation of the Product or in any event caused by incorrect and/or unsuitable and/or improper installation;
 - faults and/or defects resulting from failure to comply with indications laid out in the "Instruction, Use and Maintenance Manual" with regards to use and/or maintenance operations and/or storage of the Product or in any event caused by incorrect and/or unsuitable and/or improper use and/or maintenance operations and/or storage;
 - faults and/or defects due to normal wear and tear of the Product and/or its parts and/or its components;
 - faults and/or defects in the Product and/or its parts and/or its components for work and/or repairs being carried out by unskilled staff or staff that has not been authorised by Bardiani Valvole S.p.A.;
 - faults and/or defects in the Product and/or its parts and/or its components caused by its being dropped and/or banged and/or dented and/or misused and/or tampering and/or breakage and/or accidents and/or any other event caused by negligence and/or carelessness and/or neglect by the Buyer and in general for any causes not ascribable to design and/or manufacturing and/or material defects;
 - faults and/or defects in the Product and/or its parts and/or its components caused by other events beyond the control of Bardiani Valvole S.p.A., such as force majeure or unforeseeable circumstances.

15 Recommendations

1. Consultation of the "Instruction, Use and Maintenance Manual" is mandatory prior to the installation, use and maintenance of the products of all Products. All the information, indications, specifications, technical details provided herein are based on test data which the Manufacturer Bardiani Valvole S.p.A. holds to be reliable nevertheless the above is not deemed to be assumed as fully exhaustive inasmuch as not every possible use has been envisaged.

2. All the illustrations and drawings provided are to be intended as indicative and therefore not binding, the Products illustrations being for presentation purposes only.

3. It is the Buyer's duty to assess the suitability of the products for the use he intends to make of the same prior to placing the order as he/she will take the risks and accept liability in case of incorrect choice and use of the Products.

4. The Manufacturer strongly recommends the Buyer to contact their sales team and request any information that might be needed in relation to the specifications and uses of the Products.

5. The information provided in this manual refers to the standard products manufactured by Bardiani Valvole S.p.A. and therefore cannot be assumed to apply to customized products as well.

6. Bardiani Valvole S.p.A. reserves the right to amend and/or integrate and/or update the data and/or information and/or technical details relative to Products at any time and without prior notice. Please visit the website www.bardiani.com, where the latest updated of the "Instruction, Use and Maintenance Manual" can be found".

7. The content and validity of the warranty covering the Products of Bardiani Valvole S.p.A are dealt with in the relevant section in the "Instruction, Use and Maintenance Manual" which constitutes an integral part of the Products themselves.

8. Bardiani Valvole S.p.A., shall not in any way be held liable for immaterial, indirect and consequential damages, such as (by way of example only), damages or loss of business, contracts, opportunities, time, production, profits, goodwill, image etc..

NOTES

NOTES

Bardiani Valvole S.p.A.

via G. di Vittorio, 50/52 - 43045 Fornovo di Taro (PR) - Italy

tel. +39 0525 - Fax 0525 3408

bardiani@bardiani.com - www.bardiani.com